

## REGULATORS FOR LOW VACUUM LEVELS

The regulators described in this page are based on the same operation principle as the ones described in the previous page and have the same function. The only difference is that in these ones the minimum adjustable vacuum level is close to the atmospheric pressure value. The vacuum level is adjusted by rotating the special reeded screw clockwise to increase it, and anti-clockwise to reduce it.

### Technical features

- Operation: membrane-piston regulator.
- Adjustable operating pressure: from 980 to 1 mbar abs.
- Capacity: from 20 to 160 cum/h.
- Room temperature: from -10 to +80 °C.
- Installation position: any.

### Use

These regulators are used as the previously described ones, but they offer the additional advantage of regulating even vacuum levels close to the atmospheric pressure.

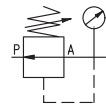
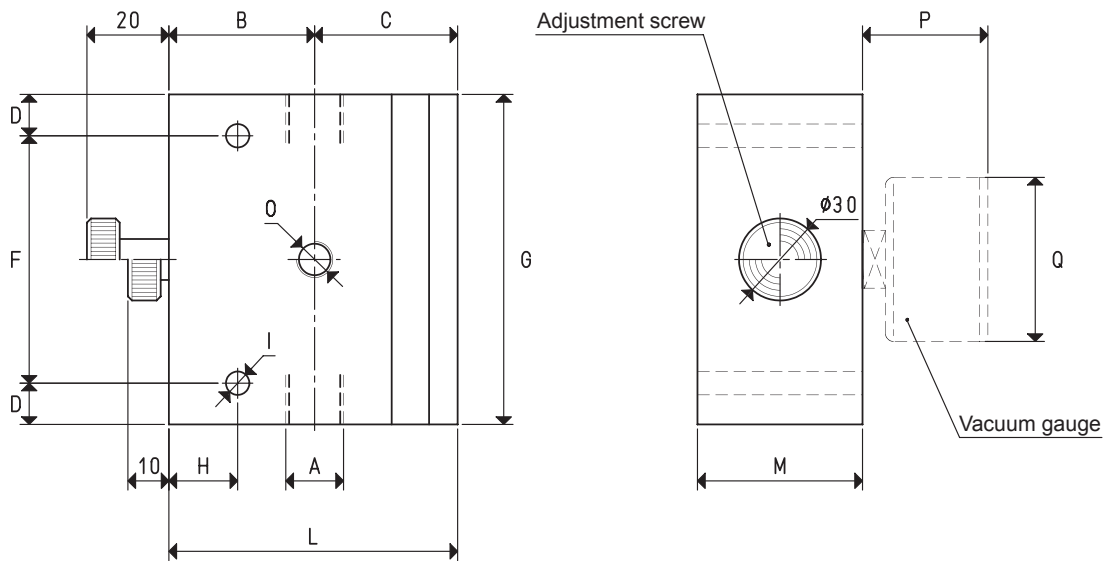

Art.	A Ø	Max. capacity cum/h	B	C	D	F	G	H	I Ø	L	M	O Ø	P	Q Ø	Art. pressure gauge	Weight Kg
11 03 50	G1/2"	20	53	52.0	15	90	120	25	8.5	105.0	60	G1/4"	36	63	09 03 10	2.07
11 05 50	G1"	80	60	58.0	15	90	120	30	8.5	118.0	100	G1/4"	36	63	09 03 10	3.74
11 06 50	G1" 1/2	160	54	77.5	15	130	160	20	8.5	131.5	99	G1/4"	36	63	09 03 10	5.54

**Note:** Pressure gauges are not integral part of the regulators, therefore, they must be ordered separately