



These cups have been created as an alternative to the ordinary cups used in the robot-automotive field and they offer an excellent solution to gripping and handling problems that could arise on vacuum-driven handlers in every industry sector.

They can be both flat and bellow-type, round and oval and equipped with support. The extremely flexible outside lip, can be associated with the typical features of the bellow cups, allow them to adapt themselves on flat, concave and convex surfaces with no risk of deforming or breaking even the thinnest objects to be handled.

The innovative design of the inside of the cups, which facilitates the drainage of oil and water, ensures a high friction coefficient with the gripping surface and, in particular, a unique grip on oil-covered metal sheets or wet glass or marble sheets. This particular feature guarantees a firm grip and, therefore, an accurate placement of the load to be handled.

The MAXIGRIP standard cups are made with our exclusive BENZ compound:

- Hardness 60÷75°Sh.;
- Working temperature between -40 and +170 °C;
- Stain-resistant;
- Excellent resistance to abrasion, water and to oils containing chlorine.

Their galvanised steel support is vulcanised onto the cup.

A wide range of accessories, such as adapters, couplers and articulated joints, allows them to be installed on any vacuum-driven handler.

Because of their universality of use, these cups can also be provided in the special compounds listed at page 21.

CIRCULAR FLAT AND BELLOW CUPS

CUPS WITH VULCANISED SUPPORT

Art.	Force Kg	A ∅	°B ∅	Ch	D ∅	d ∅	E	F	G	H	I	SW	Support material	Weight g
VRP 40 *	3.14	26	G1/4"	15	40	17	16	14	4.0	31	15	6	steel	33.6
VRP 50 *	4.90	30	G3/8"	19	50	21	18	14	5.0	33	15	6	steel	49.3
VRP 60 *	7.06	30	G3/8"	19	60	21	18	14	6.0	36	15	6	steel	55.3
VRP 80 *	12.56	35	G3/8"	19	80	21	25	14	7.5	40	15	6	steel	74.9
VRP 100 *	19.62	35	G3/8"	19	100	21	25	14	9.5	40	15	6	steel	80.7
VRP 125 *	30.66	35	G3/8"	19	125	21	33	14	12.5	48	15	6	steel	139.6

\* Complete the code indicating the compound: B= BENZ rubber; N= natural para rubber; S= silicon

° Available with NPT thread. Order example: VRP 80 NPT B

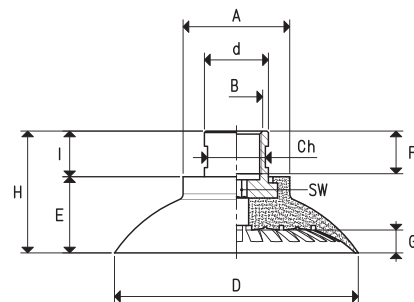

BELLOW CUP WITH VULCANISED SUPPORT

Art.	Force Kg	A ∅	B ∅	°C ∅	Ch	D ∅	d ∅	E	F	G	H	I	M ∅	Support material	Weight g
VRS 40 *	3.14	43	30	G1/4"	17	40	24	21.0	10	7.0	35.0	14	G1/8"	steel	56.3
VRS 50 *	4.90	53	40	G3/8"	22	50	34	21.0	10	7.0	36.0	15	G1/4"	steel	77.6
VRS 60 *	7.06	63	50	G3/8"	22	60	44	21.0	10	7.0	36.0	15	G1/4"	steel	107.9
VRS 80 *	12.56	83	70	G3/8"	22	80	64	23.0	10	9.0	38.0	15	G1/4"	steel	205.9
VRS 100 *	19.62	103	80	G3/8"	22	100	79	29.0	10	13.0	44.0	15	G1/4"	steel	269.0
VRS 125 *	30.66	128	105	G3/8"	22	125	100	32.5	10	16.5	47.5	15	G1/4"	steel	464.2

\* Complete the code indicating the compound: B= BENZ rubber; N= natural para rubber; S= silicon

° Available with NPT thread. Order example: VRS 80 NPT B

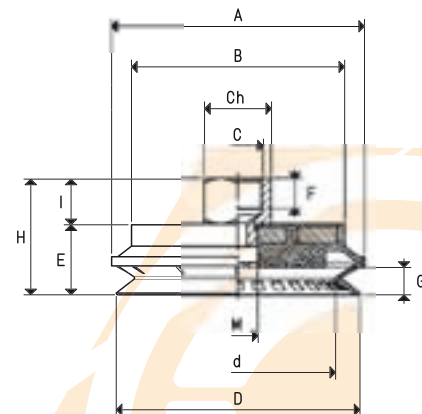

3D drawings available at [www.vuototecnica.net](http://www.vuototecnica.net)