

BELLOW CUP WITH VULCANISED SUPPORT

1



The main feature of these BELLOW CUPS is that they quickly crumple up during the grip, thus lifting the load for a few centimetres, independently of the movements of the lifting frame; this quick movement avoids that the load beneath, remains stuck to the lifted one.

Due to this feature they are particularly suited for handling thin metal sheets, glass sheets, chipboard or compressed wood panels, laminated plastic etc.

Due to their high flexibility they can also be used to compensate flatness errors or for the grip of inclined surfaces.

These BELLOW CUPS are vulcanised onto a galvanised steel or aluminium support provided with a central threaded hole for fastening it to the machine and a side one for the vacuum connection or for detecting the vacuum level. Also these cups are available in the three standard compounds.

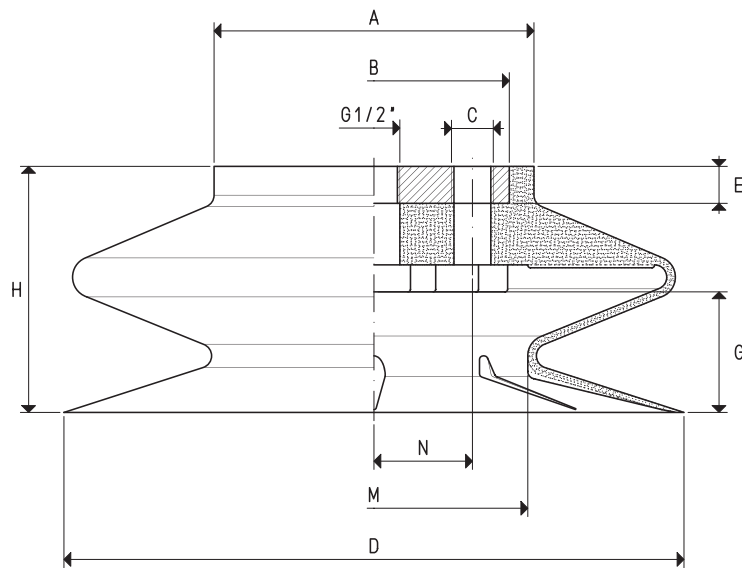

BELLOW CUP WITH VULCANISED SUPPORT

Art.	Force Kg	A ∅	B ∅	C ∅	D ∅	E	G	H	M ∅	N	Support material	Weight Kg
08 110 30 *	23.7	78	65	G1/8"	110	10	23	45	55	23	steel	0.35
08 150 30 *	45.0	78	65	G1/8"	150	10	33	60	75	23	steel	0.49
08 180 30 *	63.5	94	80	G1/8"	180	10	33	70	84	30	steel	0.81
08 250 30 *	122.6	130	100	G3/8"	250	15	49	100	125	35	aluminium	1.54

* Complete the code indicating the compound: A= oil-resistant rubber; N= natural para rubber; S= silicon