

## [Small cup holders with plunger valve, unsprung]

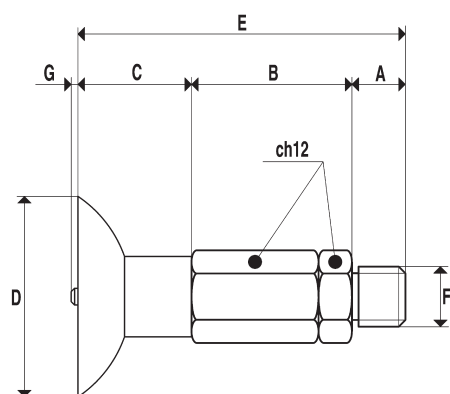

They have the same function as the previously described small cup holders with plunger valve, but in order to further reduce overall dimensions, the cushioning spring, the threaded pipe with nuts for fixing to the machine and the rapid fitting have been removed.

This kind of cup holder should be directly assembled onto the vacuum manifold; in order to allow a quick assembly, the final part is provided with a threaded spigot.

N.B.

Cups are not included in the following part numbers of the cup holder and therefore, they must be ordered separately.

Art.	Force Kg.	A	B	C	D Ø	E	F Ø	G	Art. Cup
20 12 61	0.28	8	24	11	12	43	1/8"	1	01 12 10
20 15 61	0.44	8	24	12	15	44	1/8"	1	01 15 10
20 18 61	0.63	8	24	12	18	44	1/8"	1	01 18 10
20 20 61	0.78	8	24	12	20	44	1/8"	1	01 20 10
20 22 61	0.95	8	24	13	22	45	1/8"	1	01 22 10
20 25 61	1.23	8	24	16	25	48	1/8"	1	01 25 15
20 30 61	1.76	8	24	17	30	49	1/8"	1	01 30 15
20 35 61	2.40	8	24	16	35	48	1/8"	1	01 35 15
20 40 61	3.14	8	24	18	40	50	1/8"	1	01 40 15