

[Special cup holders for bellows cups]

Designed for gripping and the lifting heavy slabs or panels and to bear hard and continuous duties in particularly dusty or damp environments, these special cup holders consist of:

- A chromium plated steel stem for attachment to the cup, complete with a rapid fitting connection to the suction hose.
- A brass threaded support, with self-lubricating bushes, supplied with two ring nuts for fastening the cup holder to the machine.
- A spring to cushion the impact of the cup with the load being lifted.
- A special bellows cup that can be supplied in different diameters and compounds, to be specified when ordering.

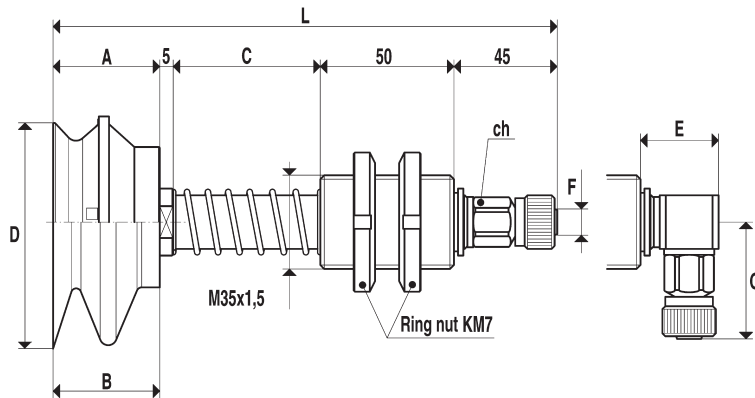

N.B.

Cups are not included in the following part numbers of the cup holder and therefore, they must be ordered separately.

The real strokes are:

C = 55	mm 37
C = 110	mm 84

Cup holder with rapid straight fitting for plastic hose $\varnothing 9 \times 12$

Art.	Force Kg.	A	B	*C	D Ø	E	F Ø	G	ch	L	Art. Cup
06 75 42	11.93	42	--	55	78	32	9	51	19	197	01 75 42
06 110 30	23.74	--	45	55	110	32	9	51	19	200	08 110 30
06 110 58	23.74	58	--	55	110	32	9	51	19	213	01 110 58
06 150 30	45.00	--	60	55	150	32	9	51	19	215	08 150 30
06 150 74	45.00	74	--	55	150	32	9	51	19	229	01 150 74
06 180 30	63.50	--	70	55	180	32	9	51	19	225	08 180 30
06 250 30	122.60	--	100	55	250	32	9	51	19	255	08 250 30

N.B. - L-type fitting is supplied only upon request. * Available also with size "C" mm. 110.