

## [Suction filters]

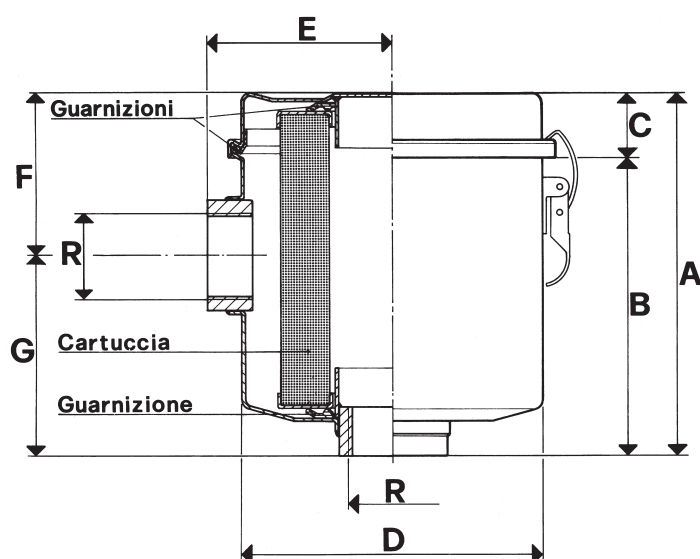

This range of filters has been made in order to permit pumps working also in very dusty environments. When installed on the suction inlet of the pumps, they are able to stop very thin or impalpable powders, interfering on the capacity in an almost negligible way.

Actually, the filtering element is made of special treated paper, with a porosity degree of  $5 \div 7$  micron, pleated to increase the filtering surface and contained in a double case of strong punched plate. The container of the filtering element, as well as the cover, are made in steel plate and painted with a special treatment for avoiding oxidation.

A gasket placed between the cover and the container assures a perfect vacuum seal between the two elements; the release clamps, placed on the container, permit a quick opening of the cover to check or replace the filtering element.

As the filtering element is made of paper, we do not recommend the use of these filters in presence of water or oil vapours or condensates.

At present they are available for capacities from 10 to 680 cum/h.

Art.	A	B	C	D	E	F	G	R	Max cap. cum/h
			Ø					Ø	
FC 10	79	70	9	72	49	37	42	3/8"	10
FC 20	93	80	13	96	67	51	42	1/2"	20
FC 25	93	80	13	96	67	51	42	3/4"	40
FC 30	105	91	14	120	82	44	61	1"	70
FC 35	96	81	15	120	82	44	52	1"1/4	100
FC 40	161	125	36	162	102	77	84	1"1/4	150
FC 50	197	161	36	160	100	85	112	1"1/2	200
FC 60	258	235	23	185	115	126	132	2"	300
FC 80	270	246	24	185	125	126	144	3"	680