

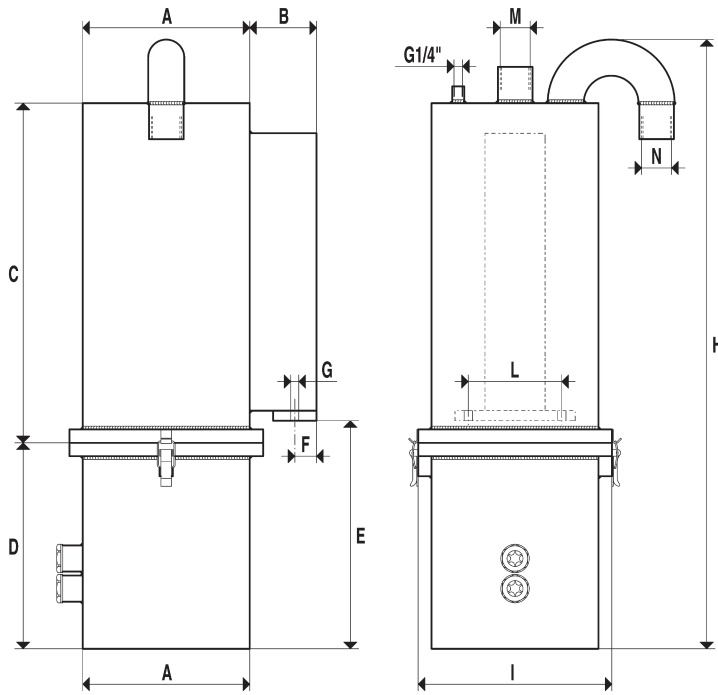

## [Long operation autonomy oil-bath suction filters]



Art.	A Ø	B	C	D	E	F	G Ø	H	I Ø	L	M Ø	N Ø	Max cap. cum/h
F0160	250	100	508	308	356	32.5	12	910	290	140	1"1/2	1"1/2	200
F0300	350	80	508	308	356	32.5	12	920	390	200	2"	2"	300

In applications which experience very thin or impalpable powders, the traditional suction filter would require a cartridge having so thick meshes which, besides decreasing its autonomy, would also considerably reduce the suction capacity of the vacuum pump.

Oil-bath suction filters have been studied in order to overcome this problem.

Besides having a long operation autonomy, the main feature of these filters is the ability to retain the thinnest and most impalpable dust, without reducing the suction capacity of the pump.

They are made by a head and a container in steel plate, coupled with an interposed seal and clamped by release clamps.

Inside the filter, besides the oil bowl, there are two filtering cartridges, which are detachable and washable; rapidity in access for servicing is guaranteed by the release clamps.

The oil level and its clogging can be checked by means of two oil windows.

For these filters it is possible to use any kind of oil, also run-down, provided that it still has a minimum viscosity degree.

At the moment they are available for capacities of 200 and 300 cum/h.