

[Syphon filters]

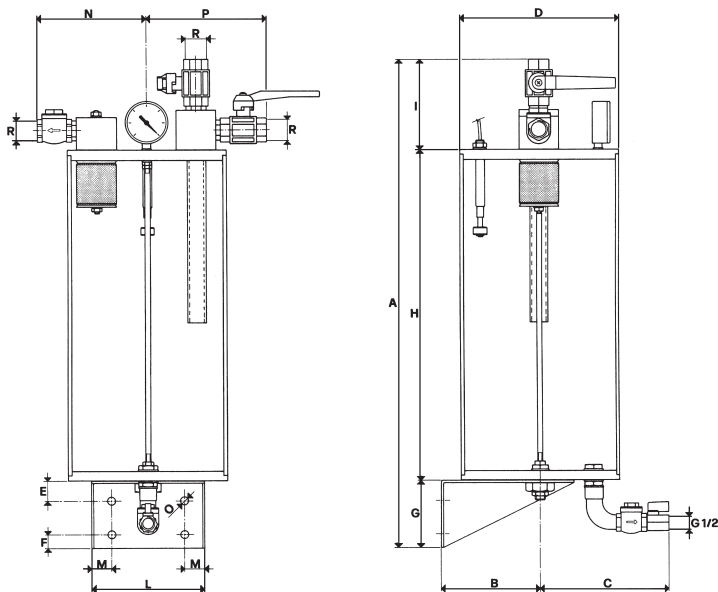

The function of these filters is to retain impurities and liquids extracted through the cups or the vacuum operated stirrup systems, in order to avoid that they enter into the vacuum pumps.

They consist of:

- A cylindrical container in transparent plexiglass, with extractable cover to allow inspection and cleaning.
- A check valve placed on the suction inlet, to prevent the air re-entry into the filter, when the pump stands still.
- A filtering cartridge in stainless steel net with a porosity of 44 micron, placed on the suction inlet, to retain dust and solid impurities.
- A two-way hand operated valve for vacuum interception of the application.
- A two-way hand operated valve for restoring the atmospheric pressure inside the filter.
- A vacuum gauge for the direct reading of the vacuum degree.
- A magnetic level switch with the function to stop the pump when the sucked liquid exceeds the safety level.
- A rigid pipe, connected to the application port, to convey the air flow and the sucked liquid to the bottom of the container.
- A check valve placed on the bottom of the filter, to drain automatically the sucked liquids and impurities, every time that the atmospheric pressure is restored inside the filter.
- A chock, applied on the above described check valve, which allows the manual drainage of the liquids.
- A strong metal bracket to allow mounting of the unit on a wall.

At present they are available for capacities up to 70 cum/h.

Art.	A	B	C	D	E	F	G	H	I	L	M	N	O	P	R	Max Cap cum/h	Contents lt.
				Ø									Ø	Ø			
FS 20	630	130	175	200	25	20	100	410	120	150	25	140	10	145	1/2"	20	10.5
FS 25	750	150	195	240	25	20	100	510	140	170	30	170	11	180	3/4"	40	19.5
FS 30	890	190	225	300	30	20	120	610	160	200	40	205	11	220	1"	70	38.0