

[Vacuum pumps VTL 5 and 10]

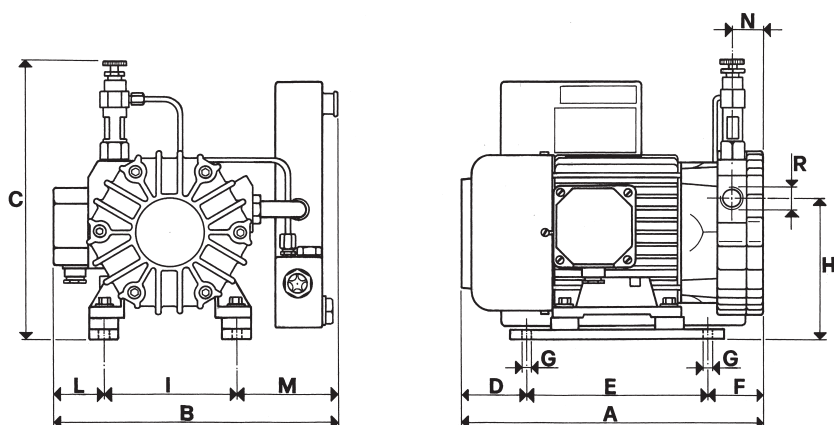

These vacuum pumps have a suction capacity of 5 and 10 cum/h.

They are lubricated by depression with loop lubrication system adjustable by means of an oiler placed in correspondence of the suction inlet. The rotor is overhanging splined to the motor shaft, therefore the overall dimensions are very small.

Motor and pump are cooled by the motor fan (surface cooling).

A tank for the oil recovery is installed on the pump outlet, this tank contains a separation filter that avoids forming of oil mists and reduces noise as well.

It is recommended to install a check valve and a suitable filter on the pump suction inlet.

Pumps VTL 5 and 10 can also be supplied with single-phase electric motor.

The table shows all data and technical features of this series of pumps.

VTL		5	10
Capacity	cum/h	5	10
Final pressure	mbar abs.	80	80
Motor execution	3 ~	230/400 ± 10%, 50 Hz	
Volt	1 ~	230 ± 10%, 50 Hz	
Motor power	3 ~	0.25	0.35
Kw	1 ~	0.25	0.25
Motor power	3 ~	0.35	0.50
Hp	1 ~	0.35	0.35
Rpm		1450	1450
Max weight	3 ~	14.5	20.5
Kg	1 ~	15.0	21.0
A		260	310
B		245	262
C		245	245
D		52	70
E		155	155
F		53	85
G	∅	8.5	8.5
H		122	122
I		115	115
L		45	45
M		85	102
N		27	52
R	∅ gas	3/8"	1/2"