



SERVO-CONTROLLED 3-WAY VACUUM SOLENOID VALVES

3D drawings are available on vuotecnica.net

The three-way vacuum solenoid valves in this series are two-position valves with pneumatically servo-controlled conical shutters. They can be used normally either closed or open.

They are composed of an anodised aluminium body, two HNBR shutters assembled onto a stainless steel stem, a membrane for servo-control made with special compounds and a thrust spring for the shutter return; an actuator activated by an electric coil managed the compressed air supply.

These valves allow reducing frictions and internal dynamic stresses to the minimum.

The result being a high response speed and a guarantee of long lasting duration.

The standard electric coil is fully plasticised with synthetic resin, tight execution, insulation class F (up to 155°C) compliant with EN 60664 standards, with 6.3 mm three-terminal electrical connections in compliance with EN 175301-803.

Protection degree IP 54; IP 65 with connector inserted.

Tolerance permitted on the nominal voltage value: ±10%.

Maximum absorption: 20 V.A. with AC and 18 W with DC.

The electric coil can be rotated 360°. The connector can be rotated 180° on the coil and can be supplied, upon request, with LED lights, anti-interference circuit and/or with protection devices against overvoltage and polarity reversal.

The three-way vacuum solenoid valves are used for vacuum interception on power supply units and suction palletisers, robots, feeders, bag opening units and in all those cases where rapid exchange between pump suction for vacuums and air supply into the circuit is necessary for quick restoration of atmospheric pressure.

Technical features

Operating pressure: from 0.5 to 3000 absolute mbar

Servo-control pressure (X): see table

Temperature of suctioned fluid: from -5 to +60°C

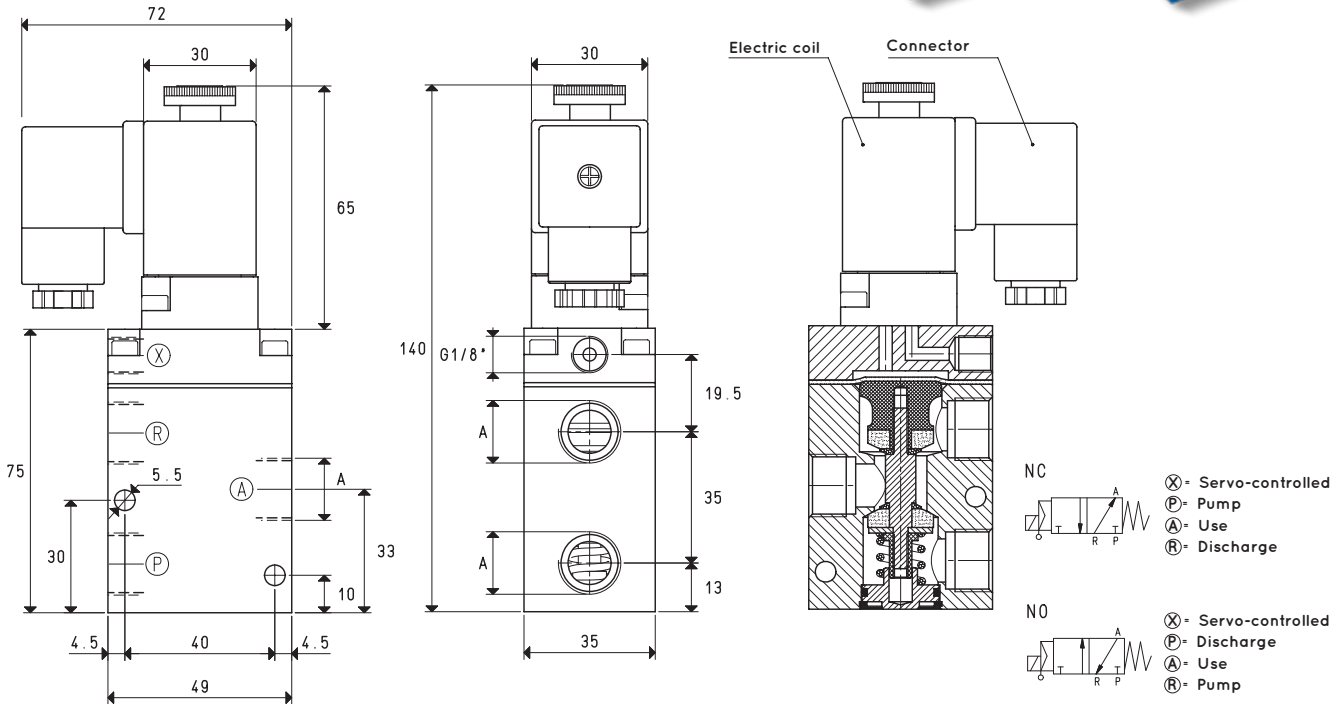

Item	A Ø	Max flow rate m³/h	Level of vacuum abs. mbar		Reaction time msec		Mouth Ø	Cross-section of passage mm²	Pressure at servo-controlled (X) *bar	Weight Kg	
			min	max	energ.	de-energ.					
07 01 11	G1/4"	6	1000	0.5	16	27	8.5	56.8	4 ÷ 7	0.56	
07 02 11	G3/8"	10	1000	0.5	16	27	11.5	103.8	4 ÷ 7	0.54	
Spare parts								07 01 11		07 02 11	
Solenoid valve sealing kit with pilot membranes					item			00 07 271		00 07 271	
Pilot membranes for solenoid valves					item			00 07 229		00 07 229	

Note: The coil and the connector are not integral parts of the solenoid valve and, therefore, must be ordered separately (See accessories for solenoid valves).

Solenoid valve servo-controlled power must be supplied with non-lubricated compressed air, 5 micron filtration, according to standard ISO 8573-1 class 4.

Transformation ratio: N (newton) = Kg x 9.81 (force of gravity)

inch = $\frac{\text{mm}}{25.4}$; pounds = $\frac{\text{g}}{453.6} = \frac{\text{Kg}}{0.4536}$

Adapters for GAS - NPT threading available on page 1.134

SERVO-CONTROLLED 3-WAY VACUUM SOLENOID VALVES

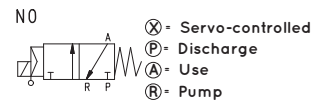
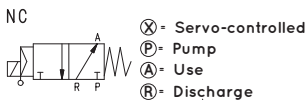
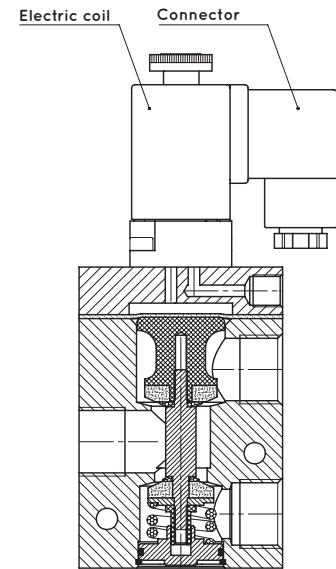
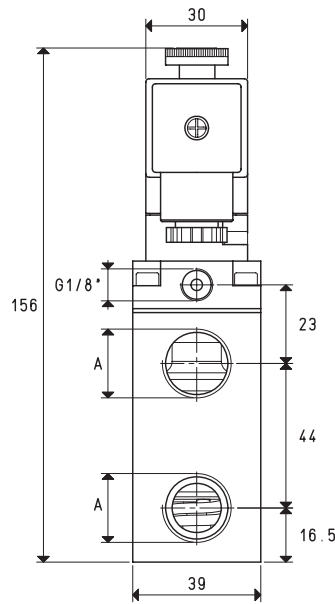
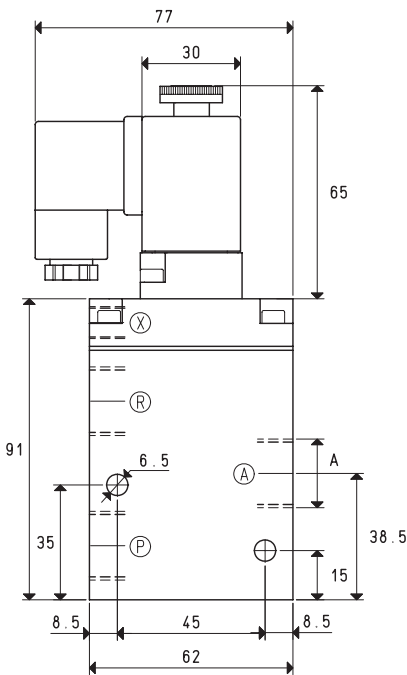

Item	A	Max flow rate	Level of vacuum	Reaction time	Mouth	Cross-section of passage	Pressure at servo-controlled (X)	Weight
	∅	m ³ /h	abs. mbar min max	msec energ. de-energ.	∅	mm ²	*bar	Kg
07 03 11	G1/2"	20	1000 0.5	16 40	15.0	176	6 ÷ 8	0.73

Spare parts				07 03 11	
Solenoid valve sealing kit with pilot membranes	item			00 07 272	
Pilot membranes for solenoid valves	item			00 07 230	

* Add the letters LP to the item for servo-controlled pressures 4 - 6 bar.

Note: The coil and the connector are not integral parts of the solenoid valve and, therefore, must be ordered separately (See accessories for solenoid valves).

Solenoid valve servo-controlled power must be supplied with non-lubricated compressed air, 5 micron filtration, according to standard ISO 8573-1 class 4.



SERVO-CONTROLLED 3-WAY VACUUM SOLENOID VALVES

3D drawings are available on vuototecnica.net

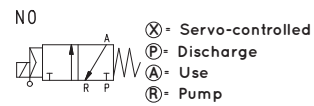
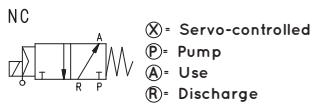
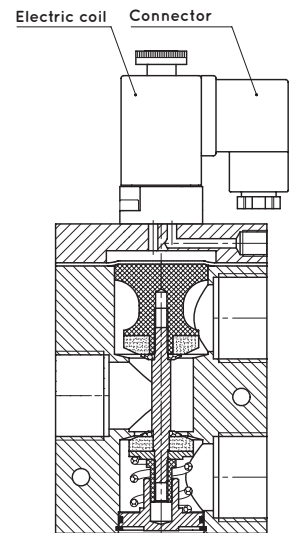
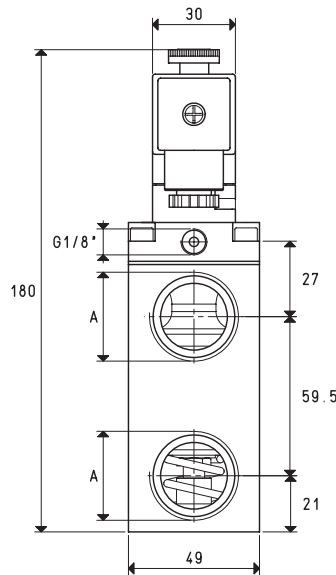
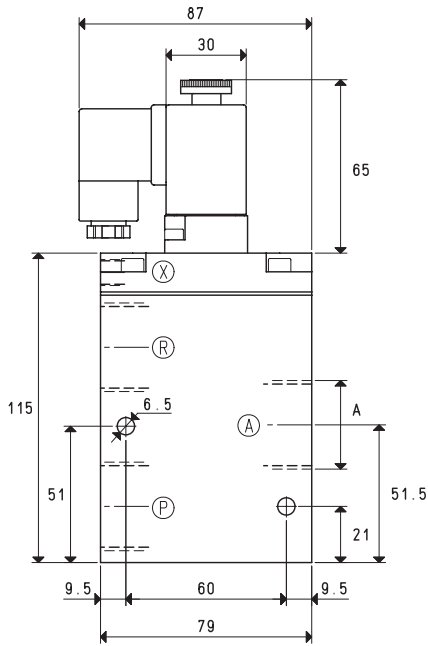

Item	A Ø	Max flow rate m ³ /h	Level of vacuum abs. mbar		Reaction time msec		Mouth Ø	Cross-section of passage mm ²	Pressure at servo-controlled (X) *bar	Weight Kg
			min	max	energ.	de-energ.				
07 04 11	G3/4"	40	1000	0.5	16	40	20	314	6 ÷ 8	1.25
07 05 11	G1"	90	1000	0.5	18	42	25	490	6 ÷ 8	1.16
Spare parts					07 04 11		07 05 11			
Solenoid valve sealing kit with pilot membranes					item	00 07 273		00 07 273		
Pilot membranes for solenoid valves					item	00 07 231		00 07 231		

* Add the letters LP to the item for servo-controlled pressures 4 - 6 bar.

Note: The coil and the connector are not integral parts of the solenoid valve and, therefore, must be ordered separately (See accessories for solenoid valves).

Solenoid valve servo-controlled power must be supplied with non-lubricated compressed air, 5 micron filtration, according to standard ISO 8573-1 class 4.

Transformation ratio: N (newton) = Kg x 9.81 (force of gravity)

inch = $\frac{\text{mm}}{25.4}$; pounds = $\frac{\text{g}}{453.6} = \frac{\text{Kg}}{0.4536}$

Adapters for GAS - NPT threading available on page 1.134

SERVO-CONTROLLED 3-WAY VACUUM SOLENOID VALVES

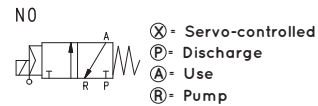
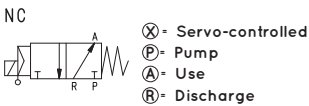
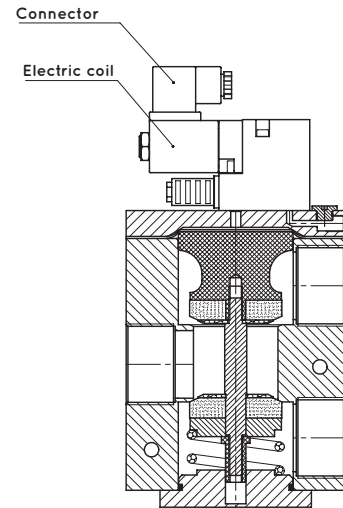
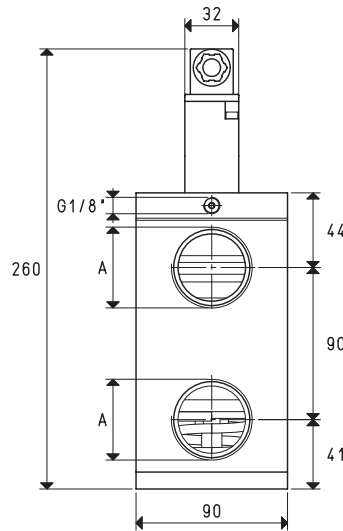
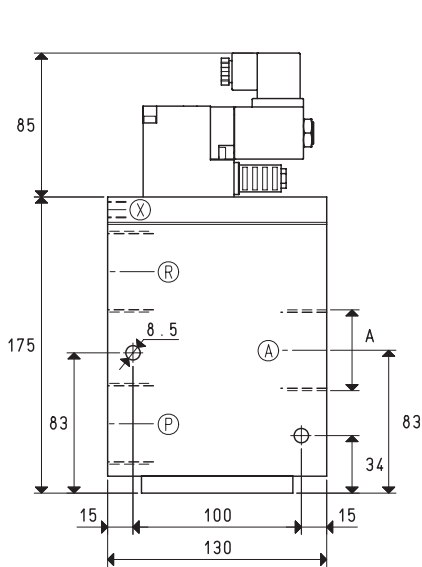

Item	A Ø	Max flow rate m ³ /h	Level of vacuum abs. mbar		Reaction time msec		Mouth Ø	Cross-section of passage mm ²	Pressure at servo-controlled (X) *bar	Weight Kg
			min	max	energ.	de-energ.				
07 06 11	G1" 1/2	230	1000	0.5	60	38	40	1256	6 ÷ 8	4.79
Spare parts							07 06 11			
Solenoid valve sealing kit with pilot membranes					item	00 07 274				
Pilot membranes for solenoid valves					item	00 07 232				

* Add the letters LP to the item for servo-controlled pressures 4 - 6 bar.

Note: The coil and the connector are not integral parts of the solenoid valve and, therefore, must be ordered separately (See accessories for solenoid valves).

Solenoid valve servo-controlled power must be supplied with non-lubricated compressed air, 5 micron filtration, according to standard ISO 8573-1 class 4.

Transformation ratio: N (newton) = Kg x 9.81 (force of gravity)

inch = $\frac{\text{mm}}{25.4}$; pounds = $\frac{\text{g}}{453.6} = \frac{\text{Kg}}{0.4536}$

Adapters for GAS - NPT threading available on page 1.134



3-WAY VACUUM SOLENOID VALVES, PILOT-OPERATED FOR LARGE CAPACITIES

Strengthened by our constant desire for research and innovation and our experience, acquired over more than forty years of operations in the vacuum sector, we have made these new solenoid valves using absolutely innovative technologies, to guarantee exceptionally low intervention times, almost negligible pressure drops, and minimal dimensions compared to the large connections with which they are equipped.

Furthermore, we have obtained them from aluminium block to eliminate even the slightest chance of loss due to transpiration, as perhaps could occur with a fusion.

This new series of solenoid valves for vacuums are three-way, two-position and are composed of:

- An anodised aluminium body set with attachment connections;
- Two conical HNBR shutters fitted on the aluminium pistons, pneumatically powered with spring return;
- An actuator, powered by an electrical coil to manage compressed air supply.

The composition of these valves, especially the original Teflon® slide system that the pistons have been equipped with, help minimise friction and internal dynamic stress, deriving high response speed and ensuring enduring operation.

They can be used normally either closed or open.

The standard electric coil of the actuator is fully plastic-coated in synthetic resin, watertight, insulation class F (up to 155°C) as per standard EN 60664, with 6.3 mm three-terminal electrical connections for connectors in compliance with EN 175301-803.

Degree of protection IP 54; IP 65 with connector inserted.

Tolerance permitted on the nominal voltage value: ± 10%.

Maximum absorption: 20 VA in AC and 18 W in DC.

The electric coil can be rotated 360°. The connector can be rotated 180° on the coil and can be supplied, upon request, with LED lights, anti-interference circuit and/or with protection devices against overvoltage and polarity reversal.

The three-way solenoid valves are used for vacuum interception on power supply units and suction palletisers, vacuum thermoformers, vacuum packaging units, robots, feeders, bag opening units and in all those cases where rapid exchange between pump suction for vacuums and air supply into the circuit is necessary for quick restoration of atmospheric pressure.

Technical features

Operating pressure: from 0.5 to 1000 absolute mbar

Servo-control pressure (X): from 4 to 8 bar

Temperature of suctioned fluid: from - 5 to + 60°C



3D drawings are available on vuototecnica.net

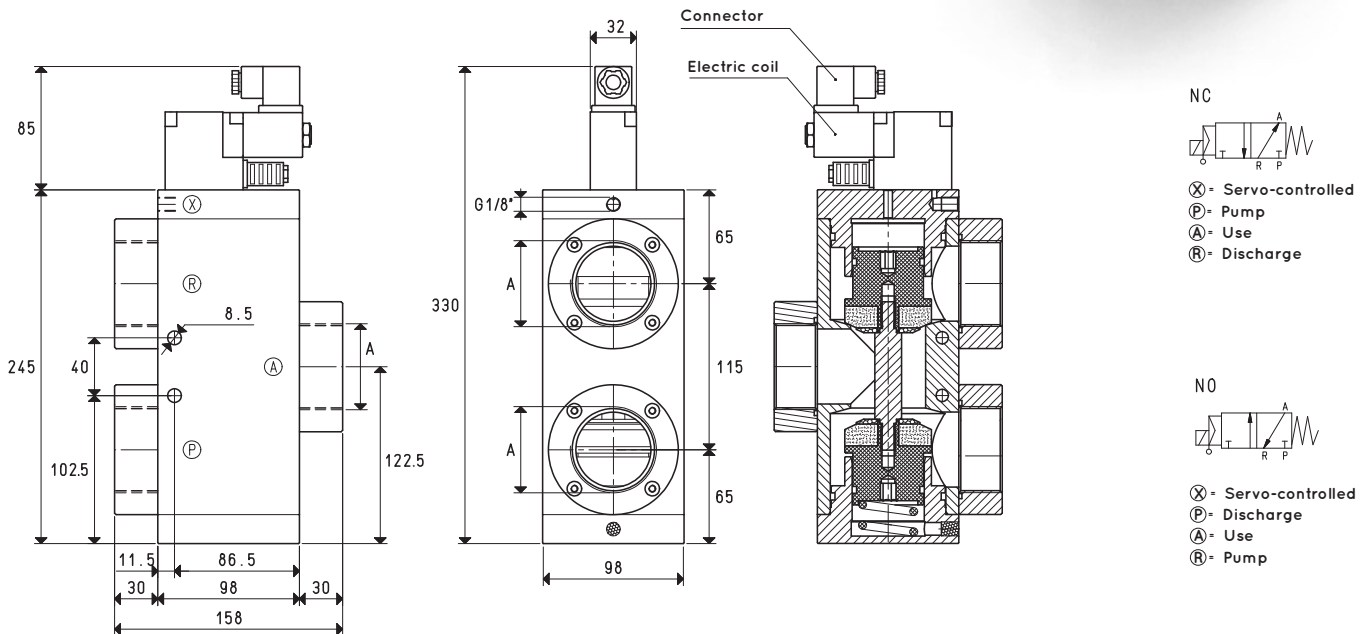

Item	A	Max flow rate m³/h	Level of vacuum abs. mbar		Reaction time msec		Mouth Ø	Cross-section of passage mm²	Pressure at servo-controlled (X) bar	Weight Kg
			min	max	energ.	de-energ.				
07 08 11	G2"	390	1000	0.5	78	50	52	2123	4 ÷ 8	5.87
Spare parts					07 08 11					
Solenoid valve sealing kit			item		00 07 372					

Note: The coil and the connector are not integral parts of the solenoid valve and, therefore, must be ordered separately (See accessories for solenoid valves).

Solenoid valve servo-controlled power must be supplied with non-lubricated compressed air, 5 micron filtration, according to standard ISO 8573-1 class 4.

Transformation ratio: N (newton) = Kg x 9.81 (force of gravity)

inch = $\frac{\text{mm}}{25.4}$; pounds = $\frac{\text{g}}{453.6} = \frac{\text{Kg}}{0.4536}$

Adapters for GAS - NPT threading available on page 1.134

3-WAY VACUUM SOLENOID VALVES, PILOT-OPERATED FOR LARGE CAPACITIES

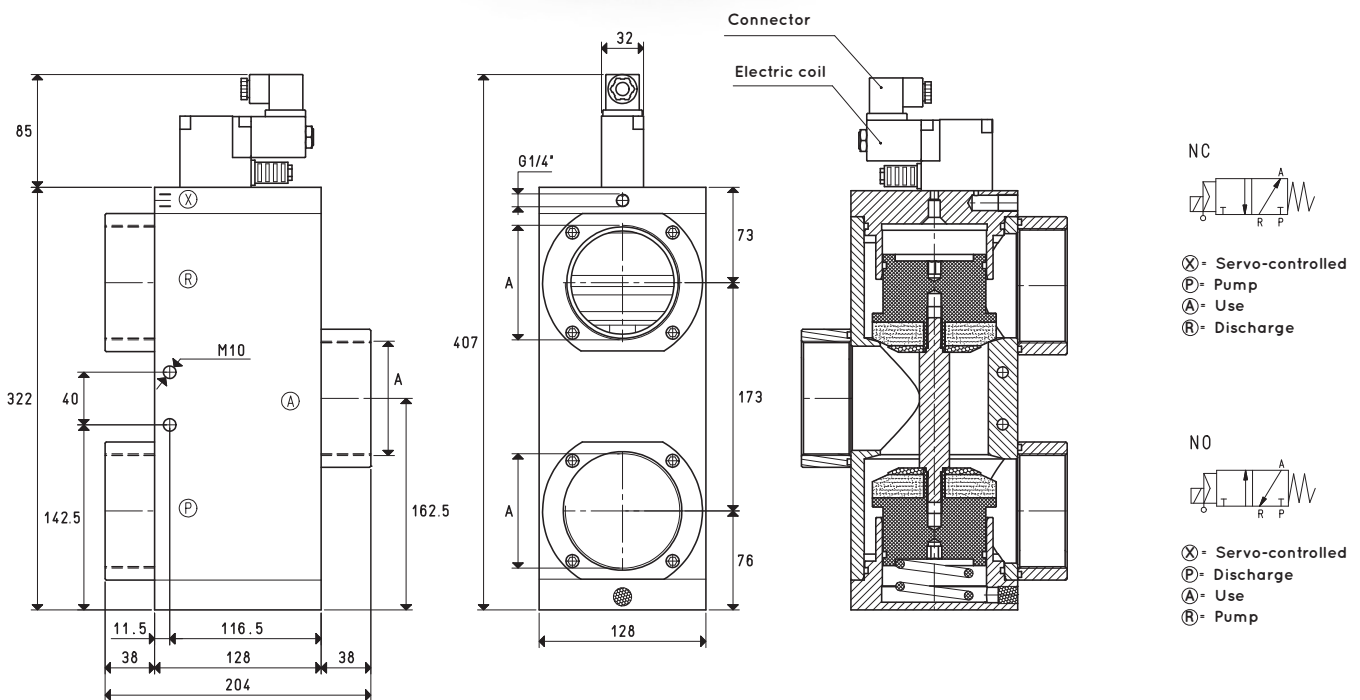

Item	A	Max flow rate m ³ /h	Level of vacuum		Reaction time		Mouth Ø	Cross-section of passage mm ²	Pressure at servo-controlled (X) *bar	Weight Kg
			abs. mbar min	max	msec energ.	de-energ.				
07 09 11	G3"	750	1000	0.5	132	84	80	5024	4 ÷ 8	11.8
Spare parts					07 09 11					
Solenoid valve sealing kit			item		00 07 382					

Note: The coil and the connector are not integral parts of the solenoid valve and, therefore, must be ordered separately (See accessories for solenoid valves).

Solenoid valve servo-controlled power must be supplied with non-lubricated compressed air, 5 micron filtration, according to standard ISO 8573-1 class 4.

Transformation ratio: N (newton) = Kg x 9.81 (force of gravity)

inch = $\frac{\text{mm}}{25.4}$; pounds = $\frac{\text{g}}{453.6} = \frac{\text{Kg}}{0.4536}$

Adapters for GAS - NPT threading available on page 1.134