



# SERVO-CONTROLLED 3-WAY VACUUM SOLENOID VALVES WITH TWO ELECTRIC COILS

3D drawings are available on [vuototecnica.net](http://vuototecnica.net)

These solenoid valves have the same function and the same structure as the previously described three-way valves. Even their structure is the same, but their distinctive features are the two coils that with a simple electric impulse exchange the shutter positions and keep them in this position till the next impulse even in absence of compressed air at the servo control and of electric current.

This is the reason why their use is especially recommended in all those cases requiring maximum connection security at the vacuum source, even in the absence of electrical and pneumatic power supply.

The standard electric coils are fully plastic-coated in synthetic resin, watertight, insulation class F (up to 155°C) as per standard EN 60664, with 6.3 mm three-terminal electrical connections for connectors in compliance with EN 175301-803.

Protection degree IP 54; IP 65 with connector inserted.

Tolerance permitted on the nominal voltage value: ±10%.

Maximum absorption: 8 - 20 V.A. with AC and 6.5 - 18 W with DC.

The electric coils can be rotated 180°. The connectors can be rotated 180° on the coils and can be supplied, upon request, with LED lights, anti-interference circuit and/or with protection devices against overvoltage and polarity reversal.

## Technical features

Operating pressure: from 0.5 to 3000 absolute mbar

Servo-control pressure (X): see table

Temperature of suctioned fluid: from -5 to +60°C

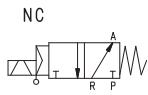
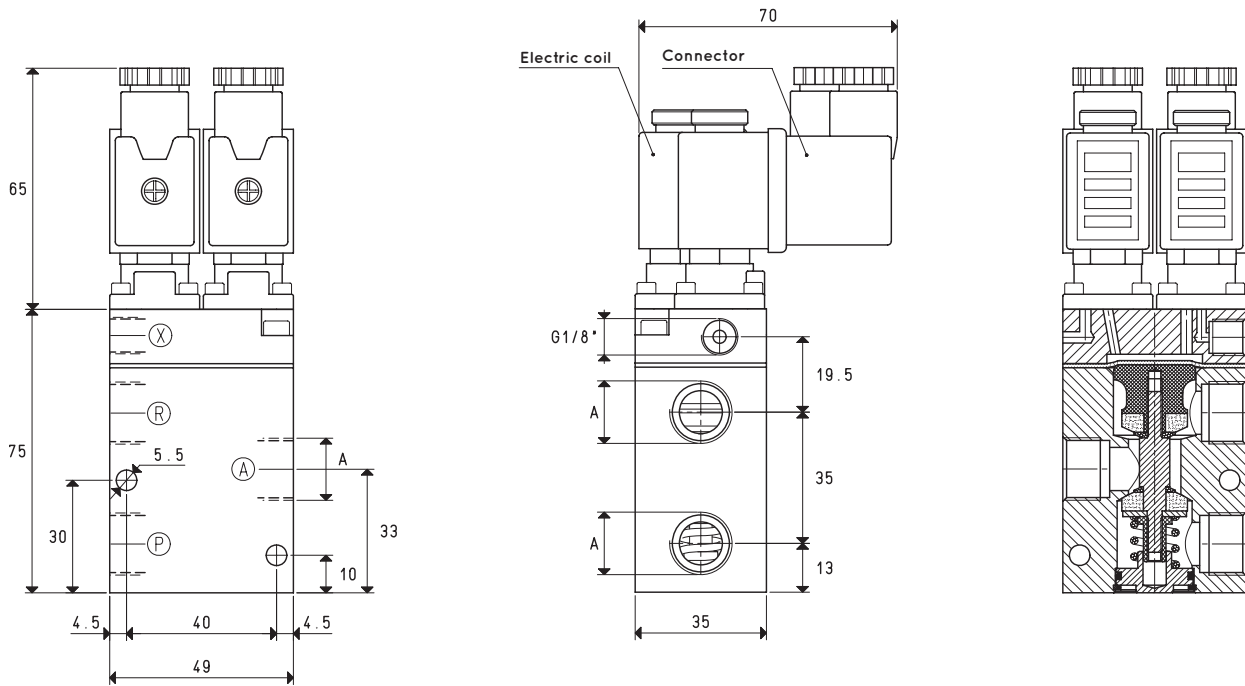

- ⊗ - Servo-controlled
- Ⓟ - Pump
- Ⓐ - Use
- Ⓡ - Discharge

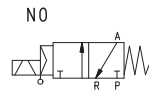

- ⊗ - Servo-controlled
- Ⓟ - Discharge
- Ⓐ - Use
- Ⓡ - Pump

Item	A Ø	Max flow rate m³/h	Level of vacuum abs. mbar		Reaction time msec		Mouth Ø	Cross-section of passage mm²	Pressure at servo-controlled (X) bar	Weight Kg	
			min	max	energ.	de-energ.					
<b>07 01 51</b>	G1/4"	6	1000	0.5	16	27	8.5	56.8	4 ÷ 7	0.59	
<b>07 02 51</b>	G3/8"	10	1000	0.5	16	27	11.5	103.8	4 ÷ 7	0.58	
<b>Spare parts</b>								<b>07 01 51</b>		<b>07 02 51</b>	
<b>Solenoid valve sealing kit with pilot membranes</b>					item	00 07 275			00 07 275		
<b>Pilot membranes for solenoid valves</b>					item	00 07 229			00 07 229		

Note: The coil and the connector are not integral parts of the solenoid valve and, therefore, must be ordered separately (See accessories for solenoid valves).

Solenoid valve servo-controlled power must be supplied with non-lubricated compressed air, 5 micron filtration, according to standard ISO 8573-1 class 4.

Transformation ratio: N (newton) = Kg x 9.81 (force of gravity)

inch =  $\frac{\text{mm}}{25.4}$ ; pounds =  $\frac{\text{g}}{453.6} = \frac{\text{Kg}}{0.4536}$

Adapters for GAS - NPT threading available on page 1.134

# SERVO-CONTROLLED 3-WAY VACUUM SOLENOID VALVES WITH TWO ELECTRIC COILS

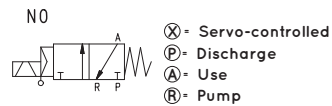
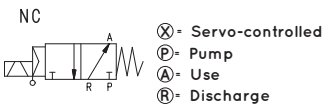
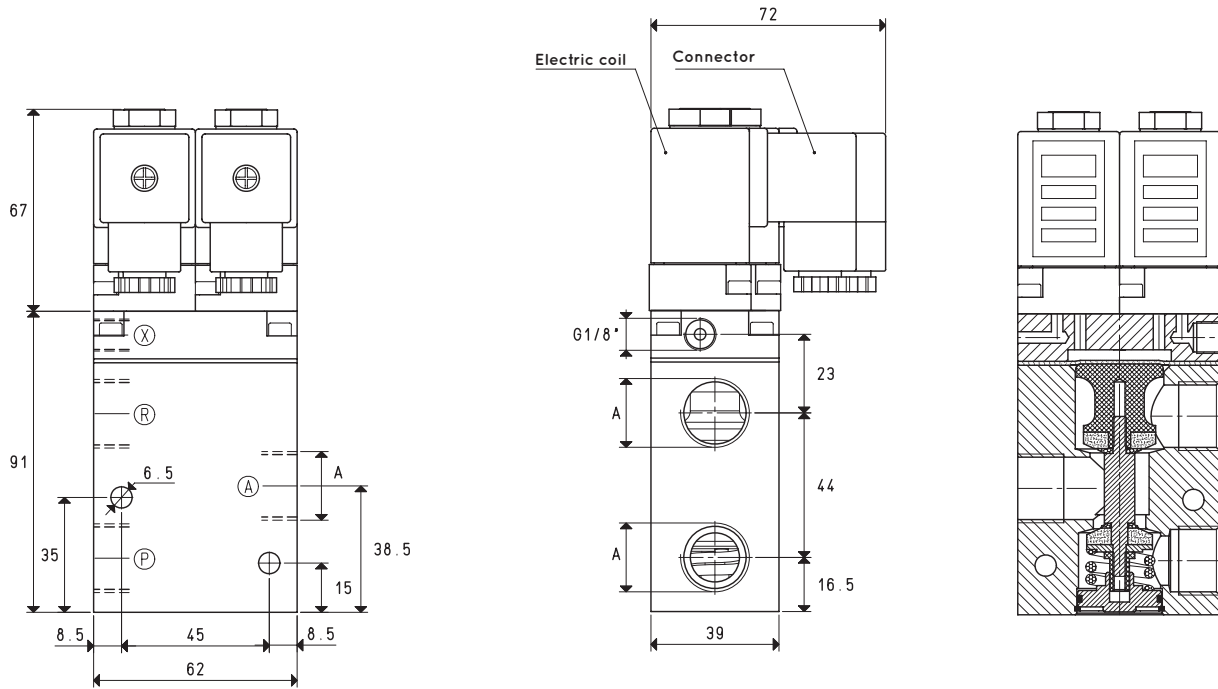

Item	A ∅	Max flow rate m <sup>3</sup> /h	Level of vacuum abs. mbar		Reaction time msec		Mouth ∅	Cross-section of passage mm <sup>2</sup>	Pressure at servo-controlled (X) *bar	Weight Kg
			min	max	energ.	de-energ.				
<b>07 03 51</b>	G1/2"	20	1000	0.5	16	40	15.0	176	6 ÷ 8	0.97
<b>Spare parts</b>					<b>07 03 51</b>					
<b>Solenoid valve sealing kit with pilot membranes</b>					item		00 07 276			
<b>Pilot membranes for solenoid valves</b>					item		00 07 230			

\* Add the letters LP to the item for servo-controlled pressures 4 - 6 bar.

Note: The coil and the connector are not integral parts of the solenoid valve and, therefore, must be ordered separately (See accessories for solenoid valves).

Solenoid valve servo-controlled power must be supplied with non-lubricated compressed air, 5 micron filtration, according to standard ISO 8573-1 class 4.

Transformation ratio: N (newton) = Kg x 9.81 (force of gravity)

inch =  $\frac{\text{mm}}{25.4}$  ; pounds =  $\frac{\text{g}}{453.6} = \frac{\text{Kg}}{0.4536}$

Adapters for GAS - NPT threading available on page 1.134



# SERVO-CONTROLLED 3-WAY VACUUM SOLENOID VALVES WITH TWO ELECTRIC COILS

3D drawings are available on [vuototecnica.net](http://vuototecnica.net)

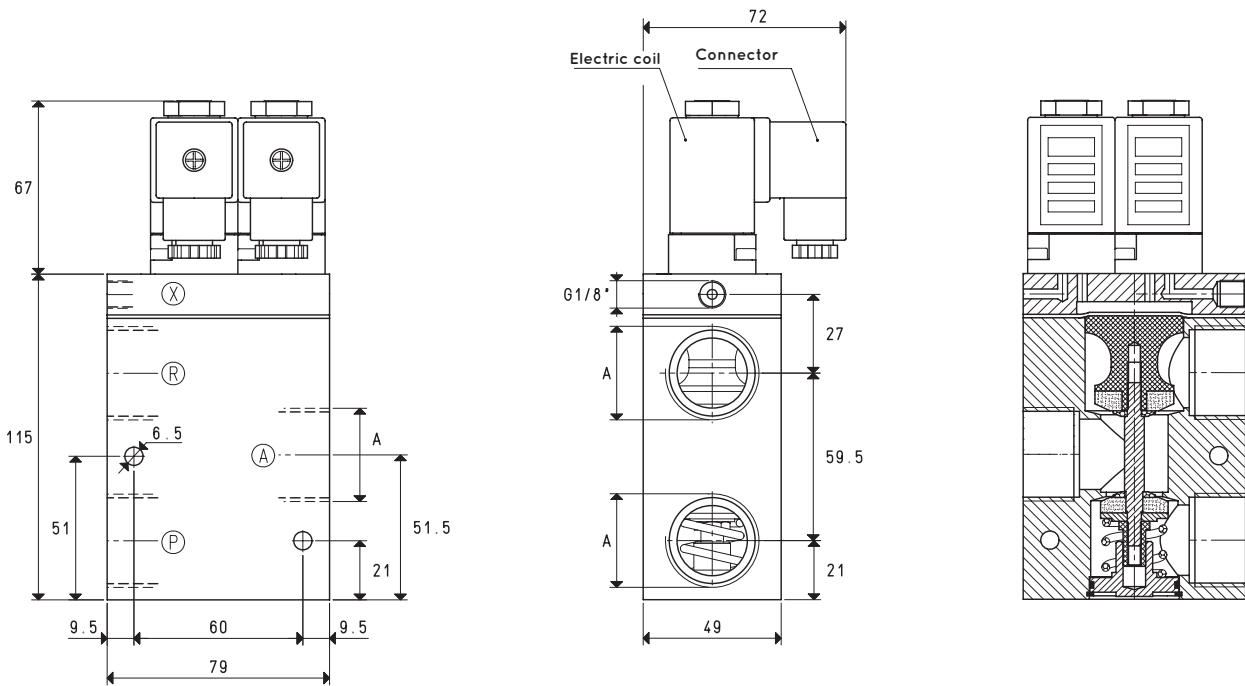

NC

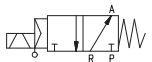

- ⊗ = Servo-controlled
- Ⓟ = Pump
- Ⓐ = Use
- Ⓡ = Discharge

NO

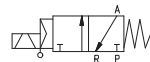

- ⊗ = Servo-controlled
- Ⓟ = Discharge
- Ⓐ = Use
- Ⓡ = Pump

Item	A Ø	Max flow rate m³/h	Level of vacuum abs. mbar		Reaction time msec		Mouth Ø	Cross-section of passage mm²	Pressure at servo-controlled (X)		
			min	max	energ.	de-energ.			*bar	Kg	
<b>07 04 51</b>	G3/4"	40	1000	0.5	16	40	20	314	6 ÷ 8		
<b>07 05 51</b>	G1"	90	1000	0.5	18	42	25	490	6 ÷ 8		
<b>Spare parts</b>								<b>07 04 51</b>		<b>07 05 51</b>	
<b>Solenoid valve sealing kit with pilot membranes</b>					item				00 07 277		
<b>Pilot membranes for solenoid valves</b>					item				00 07 231		

\* Add the letters LP to the item for servo-controlled pressures 4 - 6 bar.

Note: The coil and the connector are not integral parts of the solenoid valve and, therefore, must be ordered separately (See accessories for solenoid valves).

Solenoid valve servo-controlled power must be supplied with non-lubricated compressed air, 5 micron filtration, according to standard ISO 8573-1 class 4.

Transformation ratio: N (newton) = Kg x 9.81 (force of gravity)

inch =  $\frac{\text{mm}}{25.4}$  ; pounds =  $\frac{\text{g}}{453.6} = \frac{\text{Kg}}{0.4536}$

Adapters for GAS - NPT threading available on page 1.134

# SERVO-CONTROLLED 3-WAY VACUUM SOLENOID VALVES WITH TWO ELECTRIC COILS

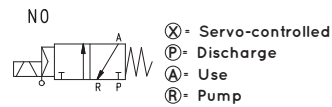
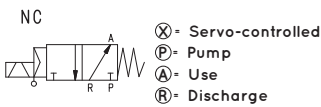
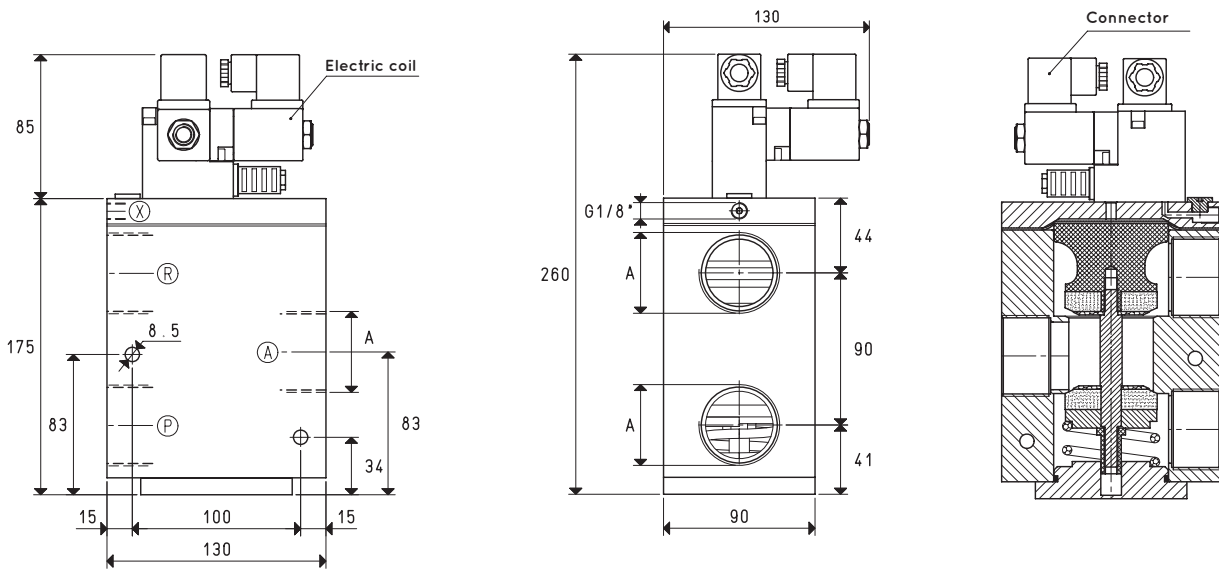

Item	A	Max flow rate m <sup>3</sup> /h	Level of vacuum abs. mbar		Reaction time msec		Mouth Ø	Cross-section of passage mm <sup>2</sup>	Pressure at servo-controlled (X) *bar	Weight Kg
			min	max	energ.	de-energ.				
<b>07 06 51</b>	G1" 1/2	230	1000	0.5	60	38	40	1256	6 ÷ 8	5.24
<b>Spare parts</b>					<b>07 06 51</b>					
<b>Solenoid valve sealing kit with pilot membranes</b>					item	00 07 278				
<b>Pilot membranes for solenoid valves</b>					item	00 07 232				

\* Add the letters LP to the item for servo-controlled pressures 4 - 6 bar.

Note: The coil and the connector are not integral parts of the solenoid valve and, therefore, must be ordered separately (See accessories for solenoid valves).

Solenoid valve servo-controlled power must be supplied with non-lubricated compressed air, 5 micron filtration, according to standard ISO 8573-1 class 4.

Transformation ratio: N (newton) = Kg x 9.81 (force of gravity)

inch =  $\frac{\text{mm}}{25.4}$  ; pounds =  $\frac{\text{g}}{453.6} = \frac{\text{Kg}}{0.4536}$

Adapters for GAS - NPT threading available on page 1.134



# SERVO-CONTROLLED 3-WAY VACUUM SOLENOID VALVES WITH TWO ELECTRIC COILS, FOR LARGE CAPACITIES

The innovative construction technology of these solenoid valves and their conformation are the same as those previously described. What differentiates them are the two simple electrical impulse coils that exchange the shutter positions and keep them in position until the next impulse even in absence of compressed air at the servo control and of electric current. This is the reason why their use is especially recommended in all those cases requiring maximum connection security at the vacuum source, even in the absence of electrical and pneumatic power supply.

The standard electric coils of the actuator are fully plastic-coated in synthetic resin, watertight, insulation class F (up to 155°C) as per standard EN 60664, with 6.3 mm three-terminal electrical connections for connectors in compliance with EN 175301-803.

Degree of protection IP 54; IP 65 with connector inserted.

Tolerance permitted on the nominal voltage value: ±10%.

Maximum absorption: 20 VA in AC and 18 W in DC.

The electric coils can be rotated 180°, as well as the connectors, which can be supplied upon request with LED lights, with an anti-interference circuit and/or with protection devices against overvoltage and polarity reversal.

## Technical features

Operating pressure: from 0.5 to 1000 absolute mbar

Servo-control pressure (X): from 4 to 8 bar

Temperature of suctioned fluid: from - 5 to + 60°C



3D drawings are available on vuototecnica.net

4

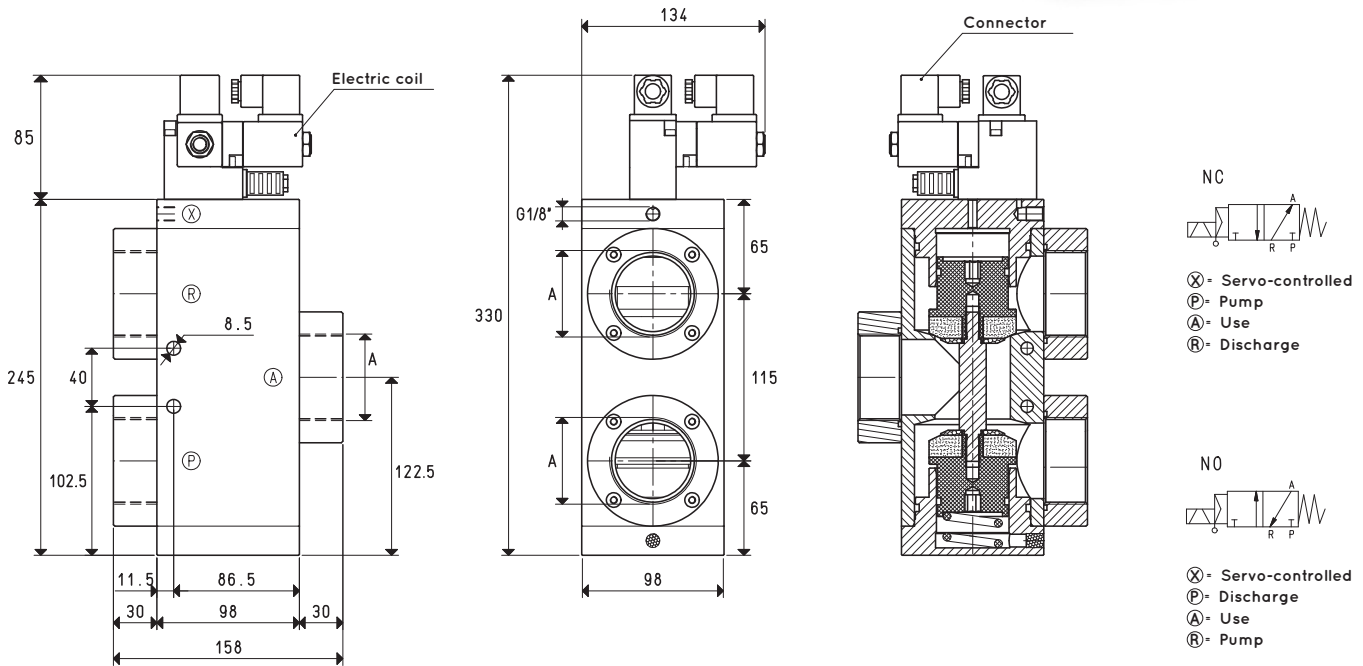

Item	A	Max flow rate	Level of vacuum		Reaction time		Mouth	Cross-section of passage	Pressure at servo-controlled (X)	Weight
			abs. mbar	min	max	msec				
<b>07 08 51</b>	G2"	390	1000	0.5	78	50	52	2123	4 ÷ 8	6.0
<b>Spare parts</b>			<b>07 08 51</b>							
<b>Solenoid valve sealing kit</b>			item	00 07 381						

Note: The coil and the connector are not integral parts of the solenoid valve and, therefore, must be ordered separately (See accessories for solenoid valves).

Solenoid valve servo-controlled power must be supplied with non-lubricated compressed air, 5 micron filtration, according to standard ISO 8573-1 class 4.

Transformation ratio: N (newton) = Kg x 9.81 (force of gravity)

inch =  $\frac{\text{mm}}{25.4}$  ; pounds =  $\frac{\text{g}}{453.6} = \frac{\text{Kg}}{0.4536}$

Adapters for GAS - NPT threading available on page 1.134

# SERVO-CONTROLLED 3-WAY VACUUM SOLENOID VALVES WITH TWO ELECTRIC COILS, FOR LARGE CAPACITIES

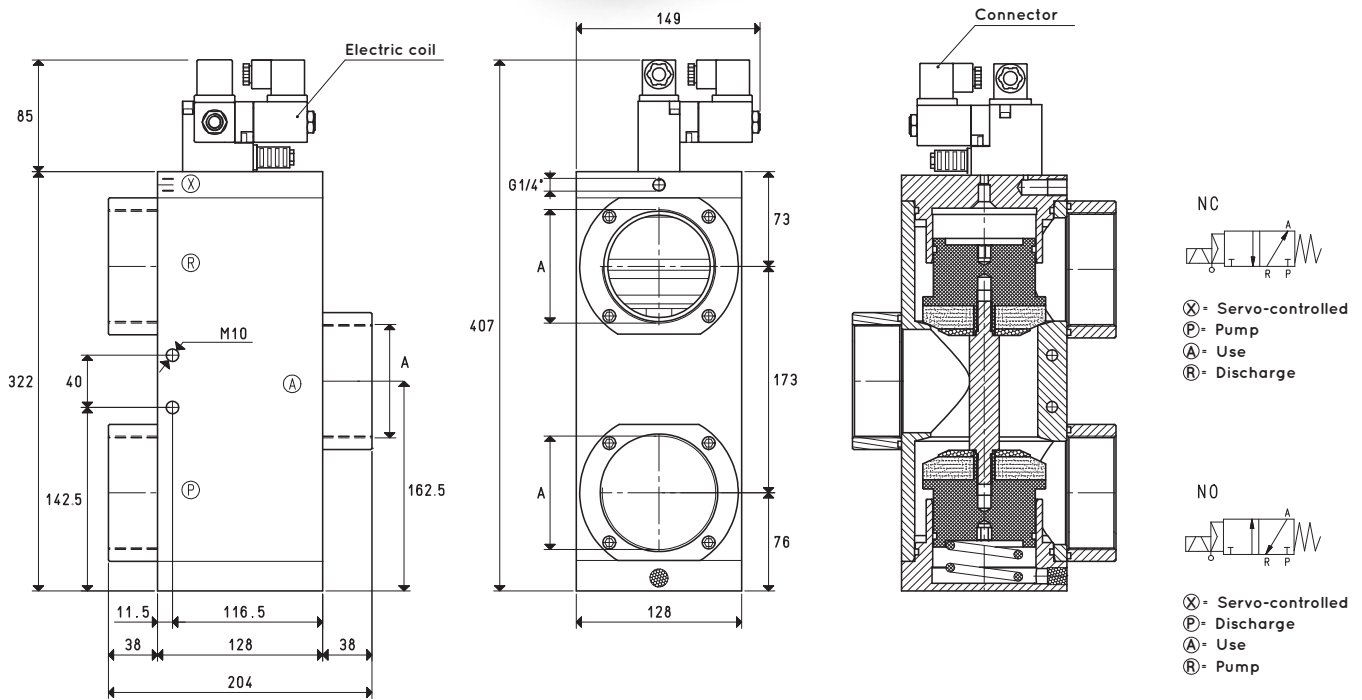

Item	A	Max flow rate m <sup>3</sup> /h	Level of vacuum abs. mbar		Reaction time msec		Mouth Ø	Cross-section of passage mm <sup>2</sup>	Pressure at servo-controlled (X) bar	Weight Kg
			min	max	energ.	de-energ.				
<b>07 09 51</b>	G3"	750	1000	0.5	132	84	80	5024	4 ÷ 8	11.8
<b>Spare parts</b>					<b>07 09 51</b>					
<b>Solenoid valve sealing kit</b>			item		00 07 385					

Note: The coil and the connector are not integral parts of the solenoid valve and, therefore, must be ordered separately (See accessories for solenoid valves).

Solenoid valve servo-controlled power must be supplied with non-lubricated compressed air, 5 micron filtration, according to standard ISO 8573-1 class 4.

Transformation ratio: N (newton) = Kg x 9.81 (force of gravity)

inch =  $\frac{\text{mm}}{25.4}$  ; pounds =  $\frac{\text{g}}{453.6} = \frac{\text{Kg}}{0.4536}$

Adapters for GAS - NPT threading available on page 1.134