



DIRECT DRIVE 2-WAY VACUUM SOLENOID VALVES

3D drawings are available on vuototecnica.net

These direct drive two-way, two-position vacuum solenoid valves in the new series feature a conical shutter servo-controlled by the vacuum.

They are normally closed, but they can be supplied normally open upon request.

They are composed of an anodised aluminium body where the connections are located, a conical silicon shutter assembled onto a stainless steel stem and a membrane in a special rubberised and coated compound. An actuator activated by an electric coil manages the vacuum at the servo-control. The operating principle of these solenoid valves is based on the pressure differential between the vacuum pump or generator and the pressure of the suctioned air. By addressing this "differential pressure" to the servo-control via the actuator, the shutter can be controlled without compressed air or springs. Due to their operating principle, they are not recommended on plants with rough vacuum levels (below 850 absolute mbar, equal to 15% vacuum).

The lack of springs, frictions and internal dynamic stresses favours a high response speed and guarantees long lasting operation of the solenoid valve.

The standard electric coil is fully plasticised with synthetic resin, tight execution, insulation class F (up to 155°C) compliant with VDE standards, with 6.3 mm three-terminal electrical connections in compliance with EN 175301-803 (ex-DIN 43650).

Protection degree IP 54, IP 65 with connector inserted.

Tolerance permitted on the nominal voltage value: $\pm 10\%$.

Maximum absorption: 20 V.A. with AC and 18 W with DC.

The electric coil can be rotated 360°. The connector can be rotated 180° on the coil and can be supplied, upon request, with LED light, anti-interference circuit and/or with protection devices against overvoltage and polarity reversal.

This series of solenoid valves can be used on vacuum systems without compressed air and in all applications where suction has to be controlled separately from the air inlet into circuit, such as degasifiers, autoclaves, vacuum thermo-welders, etc. The solenoid valve must be always chosen according to the flow rate and, therefore, to the vacuum pump or generator suction connection.

Technical features

Operating pressure: from 0.5 to 850 absolute mbar

Temperature of suctioned fluid: from - 5 to + 60°C

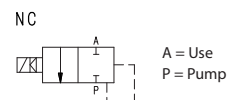
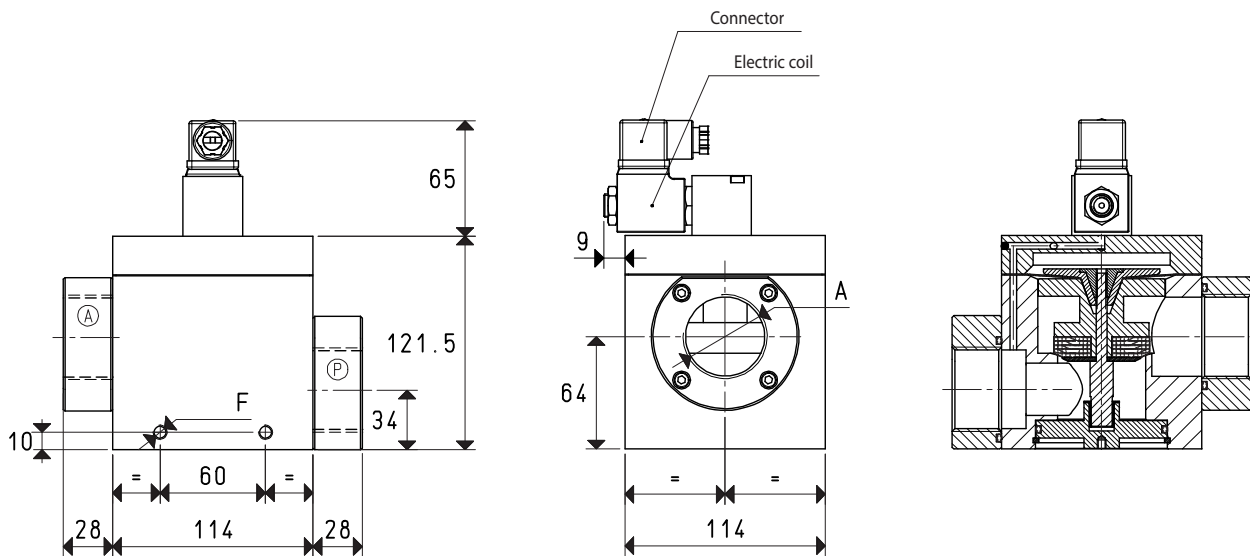

Item	A	Max flow rate m ³ /h	Level of vacuum abs. mbar		Reaction time msec		Mouth Ø	Cross-section of passage mm ²	F	Weight Kg
			min	max	energ.	de-energ.				
EGN 40 NC	G1" 1/2	230	850	0.5	75	50	40	1256	M8	4.07
					70	60				

Note: The coil and the connector are not integral parts of the solenoid valve and, therefore, must be ordered separately (See accessories for solenoid valves).

Transformation ratio: N (newton) = Kg x 9.81 (force of gravity)

inch = $\frac{\text{mm}}{25.4}$; pounds = $\frac{\text{g}}{453.6} = \frac{\text{Kg}}{0.4536}$

Adapters for GAS - NPT threading available on page 1.130

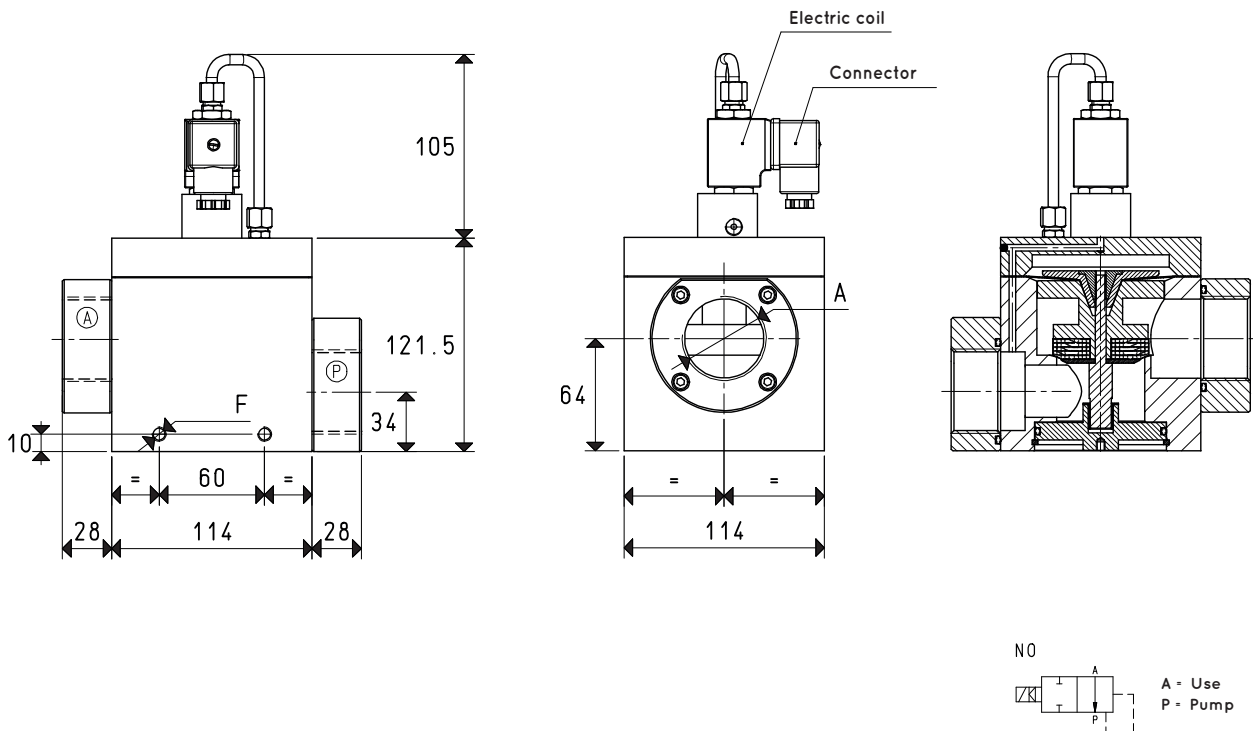

Item	A Ø	Max flow rate m³/h	Level of vacuum abs. mbar		Reaction time msec		Mouth Ø	Cross-section of passage mm²	F Ø	Weight Kg
			min	max	energ.	de-energ.				
EGN 40 NO	G1" 1/2	230	850	0.5	75	50	40	1256	M8	4.07
					70	60				

Note: The coil and the connector are not integral parts of the solenoid valve and, therefore, must be ordered separately (See accessories for solenoid valves).

Transformation ratio: N (newton) = Kg x 9.81 (force of gravity)

inch = $\frac{\text{mm}}{25.4}$; pounds = $\frac{\text{g}}{453.6} = \frac{\text{Kg}}{0.4536}$

Adapters for GAS - NPT threading available on page 1.130



DIRECT DRIVE 2-WAY VACUUM SOLENOID VALVES

3D drawings are available on vuotecnica.net

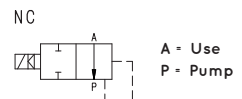
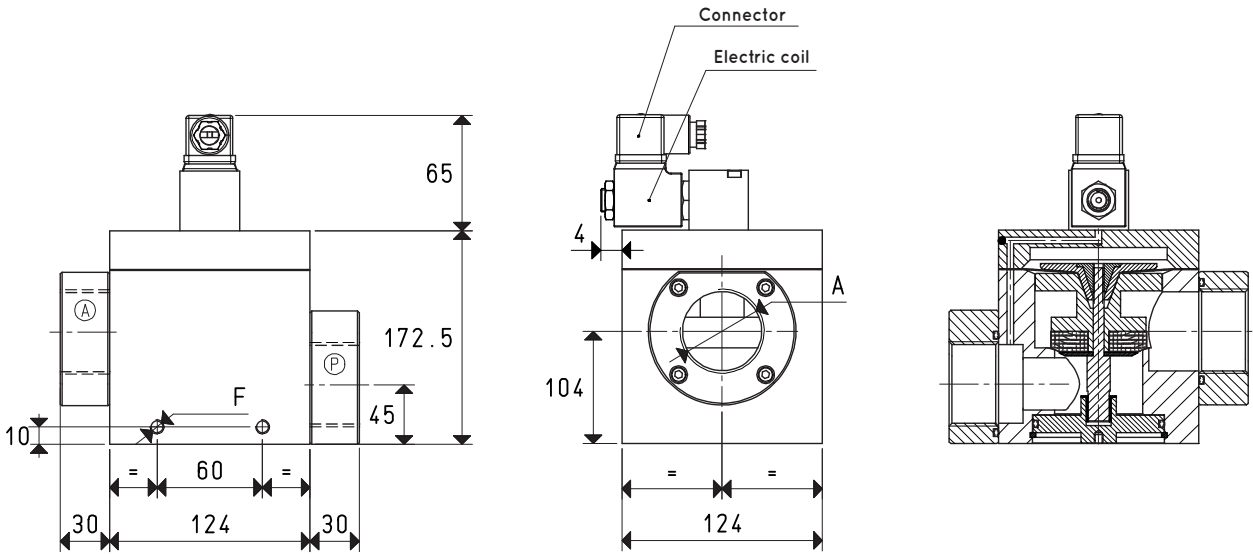
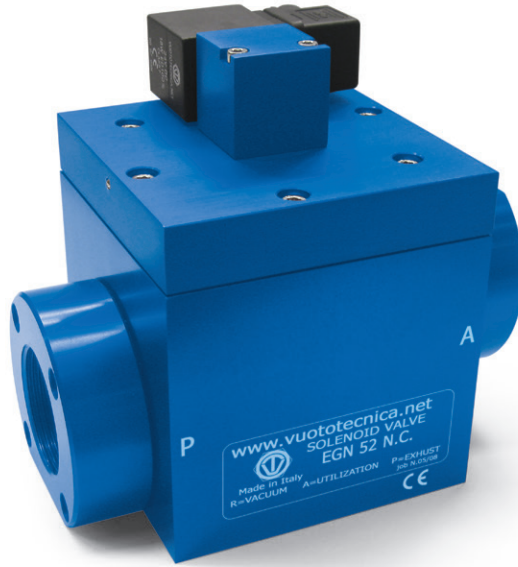

Item	A	Max flow rate m ³ /h	Level of vacuum abs. mbar		Reaction time msec		Mouth Ø	Cross-section of passage mm ²	F	Weight Kg
			min	max	energ.	de-energ.				
EGN 52 NC	G2"	390	850	0.5	75	50	52	2123	M8	6.70
					70	60				

Note: The coil and the connector are not integral parts of the solenoid valve and, therefore, must be ordered separately (See accessories for solenoid valves).

Transformation ratio: N (newton) = Kg x 9.81 (force of gravity)

inch = $\frac{\text{mm}}{25.4}$; pounds = $\frac{\text{g}}{453.6} = \frac{\text{Kg}}{0.4536}$

Adapters for GAS - NPT threading available on page 1.130

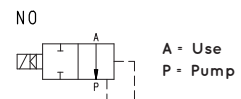
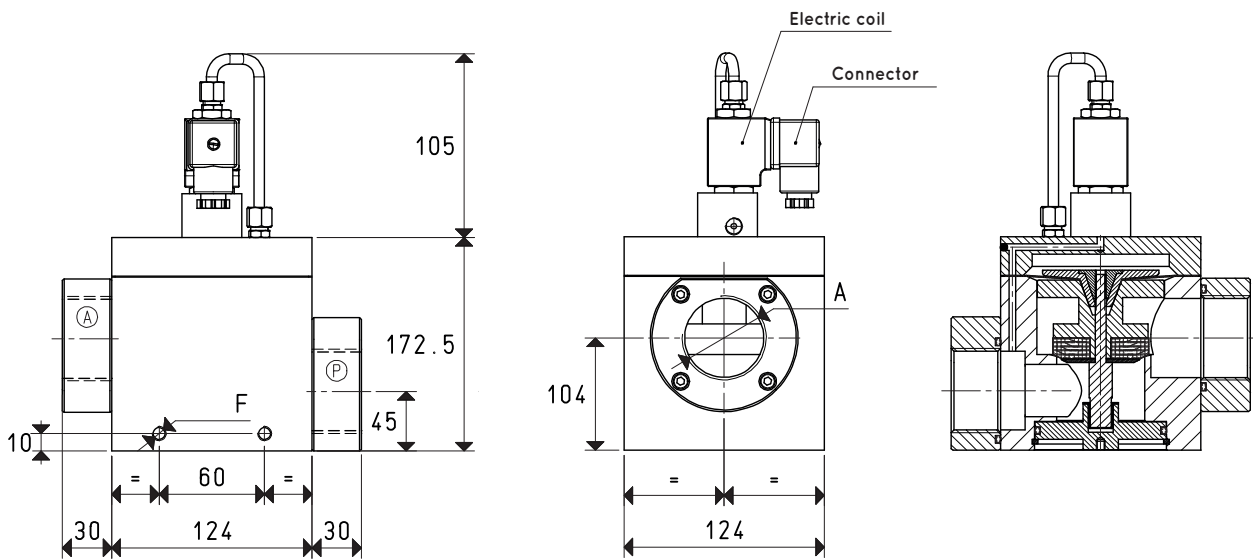
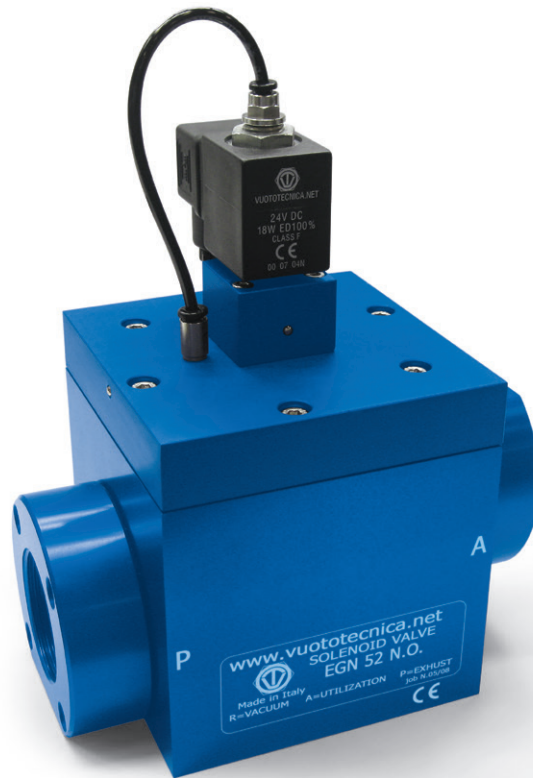

Item	A	Max flow rate m ³ /h	Level of vacuum abs. mbar		Reaction time msec		Mouth Ø	Cross-section of passage mm ²	F	Weight Kg
			min	max	energ.	de-energ.				
EGN 52 NO	G2"	390	850	0.5	75	50	52	2123	M8	6.70
					70	60				

Note: The coil and the connector are not integral parts of the solenoid valve and, therefore, must be ordered separately (See accessories for solenoid valves).

Transformation ratio: N (newton) = Kg x 9.81 (force of gravity)

inch = $\frac{\text{mm}}{25.4}$; pounds = $\frac{\text{g}}{453.6} = \frac{\text{Kg}}{0.4536}$

Adapters for GAS - NPT threading available on page 1.130