



SERVO-CONTROLLED 3-WAY VACUUM SOLENOID VALVES WITH LOW ABSORPTION ELECTRIC COIL

3D drawings are available on vuototecnica.net

The three-way vacuum solenoid valves in this series are two-position valves with pneumatically servo-controlled conical shutters.

They can be used normally either closed or open.

They are composed of an anodised aluminium body, two HNBR shutters assembled onto a stainless steel stem, a membrane for servo-control made with special compounds and a thrust spring for the shutter return; a solenoid pilot valve activated by a built-in electric coil managed the compressed air supply.

These valves allow reducing frictions and internal dynamic stresses to the minimum. The result being a high response speed and a guarantee of long lasting duration.

The electric coils of the solenoid pilot valve are fully plastic-coated in synthetic resin, watertight, insulation class F (up to 155°C) as per standard EN 60664, with 3 mm two-terminal electrical connections for connectors in compliance with EN 175301-803 - C.

Protection degree IP 54; IP 65 with connector inserted.

Available for voltages 12-24V/50-60Hz and 12-24VDC.

Tolerance permitted on the nominal voltage value: ±10%.

Maximum electric power: 2 W.

The connector can be rotated 180° on the coil and can be supplied, upon request, with LED lights, anti-interference circuit and/or with protection devices against overvoltage and polarity reversal.

A push-button device, built-in the solenoid pilot valve, allows manually opening and closing the solenoid valve.

The 3-way vacuum solenoid valves are used for vacuum interception on power supply units and suction palletisers, robots, feeders, bag opening units and in all those cases where rapid exchange between pump suction for vacuums and air supply into the circuit is necessary for quick restoration of atmospheric pressure.

Technical features

Operating pressure: from 0.5 to 3000 absolute mbar

Servo-control pressure (X): see table

Temperature of suctioned fluid: from -5 to +60°C

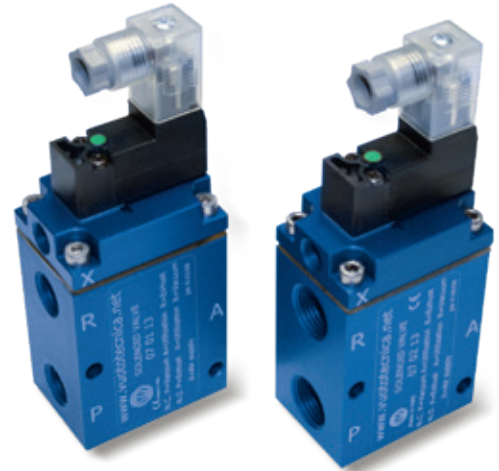

4

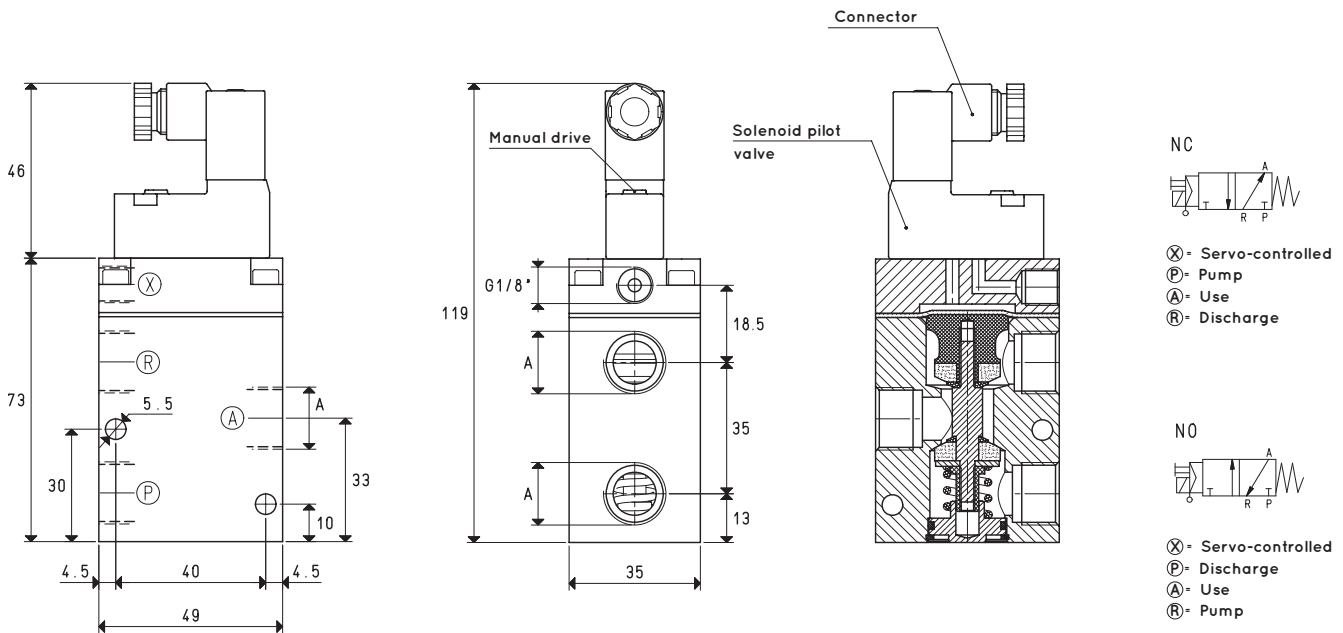

Item	A Ø	Max flow rate m³/h	Level of vacuum abs. mbar		Reaction time msec		Mouth Ø	Cross-section of passage mm²	Pressure at servo-controlled (X) bar	Weight Kg	
			min	max	energ.	de-energ.					
07 01 13	G1/4"	6	1000	0.5	16	27	8.5	56.8	4 ÷ 7	0.44	
07 02 13	G3/8"	10	1000	0.5	16	27	11.5	103.8	4 ÷ 7	0.43	
Spare parts								07 01 13	07 02 13		
Solenoid valve sealing kit with pilot membranes					item	00 07 271			00 07 271		
Pilot membranes for solenoid valves					item	00 07 229			00 07 229		

Note: Specify the voltage of the electric coil when ordering. (Example: 07 01 13 V24-CC)

The connector is not integral parts of the solenoid valve and, therefore, must be ordered separately (See accessories for solenoid valves).

Solenoid valve servo-controlled power must be supplied with non-lubricated compressed air, 5 micron filtration, according to standard ISO 8573-1 class 4.

Transformation ratio: N (newton) = Kg x 9.81 (force of gravity)

inch = $\frac{\text{mm}}{25.4}$; pounds = $\frac{\text{g}}{453.6} = \frac{\text{Kg}}{0.4536}$

Adapters for GAS - NPT threading available on page 1.134

SERVO-CONTROLLED 3-WAY VACUUM SOLENOID VALVES WITH LOW ABSORPTION ELECTRIC COIL

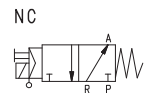
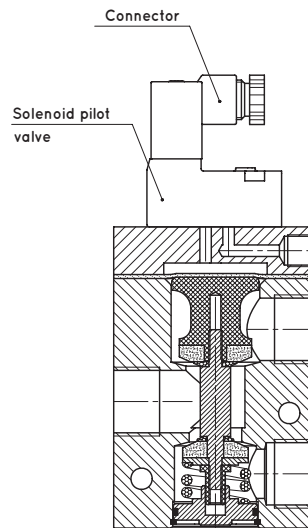
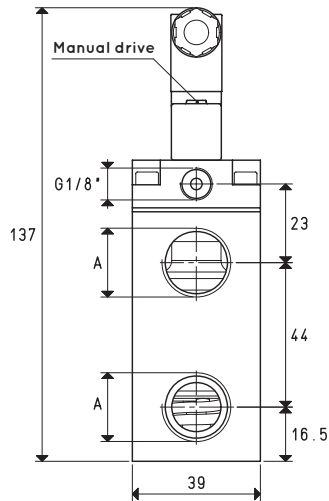
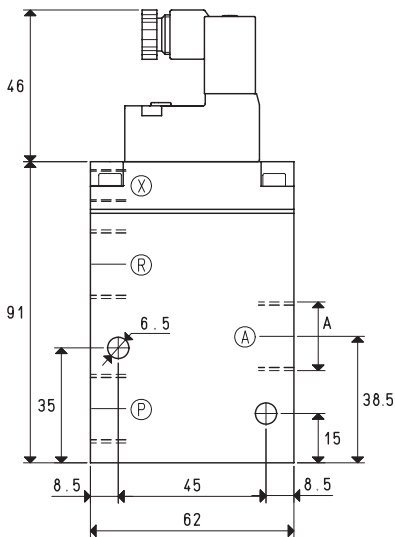

- ⊗ - Servo-controlled
- Ⓟ - Pump
- Ⓐ - Use
- Ⓡ - Discharge

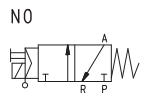

- ⊗ - Servo-controlled
- Ⓟ - Discharge
- Ⓐ - Use
- Ⓡ - Pump

Item	A Ø	Max flow rate m³/h	Level of vacuum		Reaction time		Mouth Ø	Cross-section of passage mm²	Pressure at servo-controlled (X) *bar	Weight Kg
			abs. mbar min	max	msec energ.	de-energ.				
07 03 13	G1/2"	20	1000	0.5	16	40	15.0	176	6 ÷ 7	0.52
Spare parts					07 03 13					
Solenoid valve sealing kit with pilot membranes					item		00 07 272			
Pilot membranes for solenoid valves					item		00 07 230			

* Add the letters LP to the item for servo-controlled pressures 4 - 6 bar.

Note: Specify the voltage of the electric coil when ordering. (Example: 07 03 13 V24-CC)

The connector is not integral parts of the solenoid valve and, therefore, must be ordered separately (See accessories for solenoid valves).

Solenoid valve servo-controlled power must be supplied with non-lubricated compressed air, 5 micron filtration, according to standard ISO 8573-1 class 4.

Transformation ratio: N (newton) = Kg x 9.81 (force of gravity)

inch = $\frac{\text{mm}}{25.4}$; pounds = $\frac{\text{g}}{453.6} = \frac{\text{Kg}}{0.4536}$

Adapters for GAS - NPT threading available on page 1.134



SERVO-CONTROLLED 3-WAY VACUUM SOLENOID VALVES WITH LOW ABSORPTION ELECTRIC COIL

3D drawings are available on vuototecnica.net

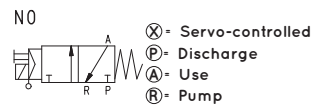
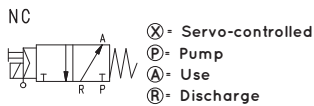
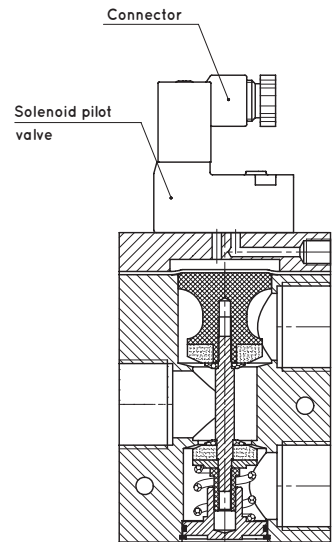
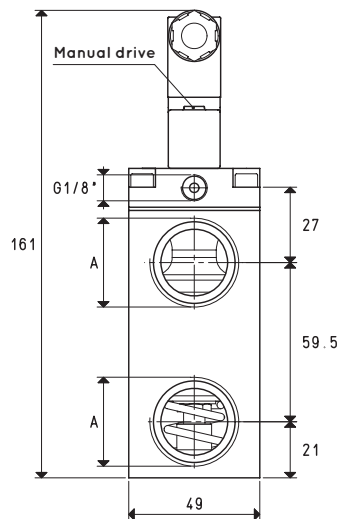
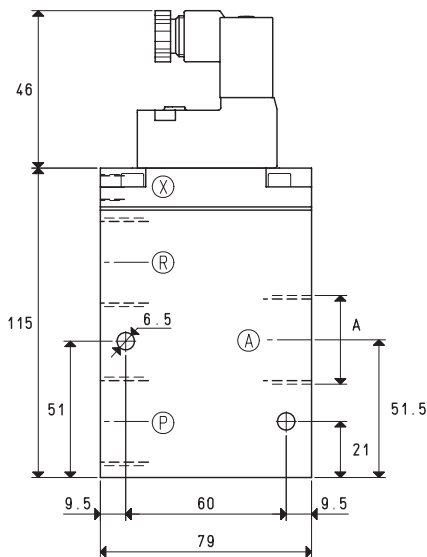

Item	A Ø	Max flow rate m³/h	Level of vacuum abs. mbar		Reaction time msec		Mouth Ø	Cross-section of passage mm²	Pressure at servo-controlled (X) *bar	Weight Kg
			min	max	energ.	de-energ.				
07 04 13	G3/4"	40	1000	0.5	16	40	20	314	6 ÷ 7	1.00
07 05 13	G1"	90	1000	0.5	18	42	25	490	6 ÷ 7	0.94

Spare parts				07 04 13	07 05 13
Solenoid valve sealing kit with pilot membranes				item	00 07 273
Pilot membranes for solenoid valves				item	00 07 231

* Add the letters LP to the item for servo-controlled pressures 4 - 6 bar.

Note: Specify the voltage of the electric coil when ordering. (Example: 07 04 13 V24-CC)

The connector is not integral parts of the solenoid valve and, therefore, must be ordered separately (See accessories for solenoid valves).

Solenoid valve servo-controlled power must be supplied with non-lubricated compressed air, 5 micron filtration, according to standard ISO 8573-1 class 4.

Transformation ratio: N (newton) = Kg x 9.81 (force of gravity)

inch = $\frac{\text{mm}}{25.4}$; pounds = $\frac{\text{g}}{453.6} = \frac{\text{Kg}}{0.4536}$

Adapters for GAS - NPT threading available on page 1.134

SERVO-CONTROLLED 3-WAY VACUUM SOLENOID VALVES WITH LOW ABSORPTION ELECTRIC COIL

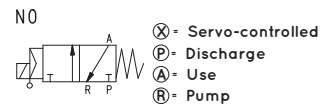
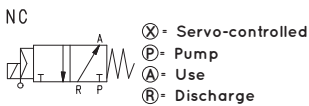
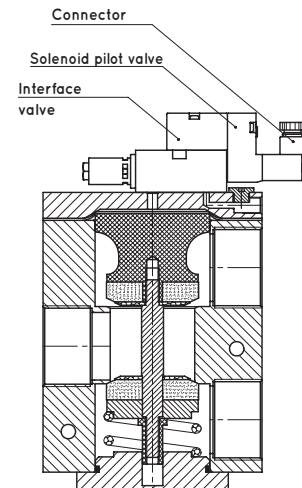
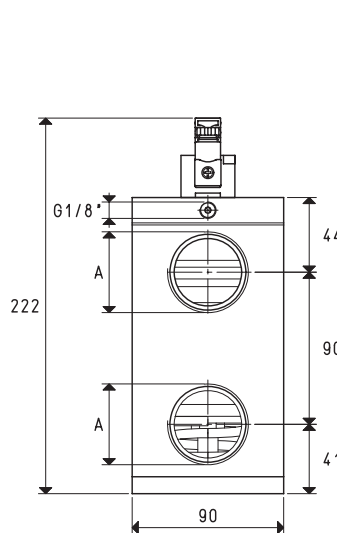
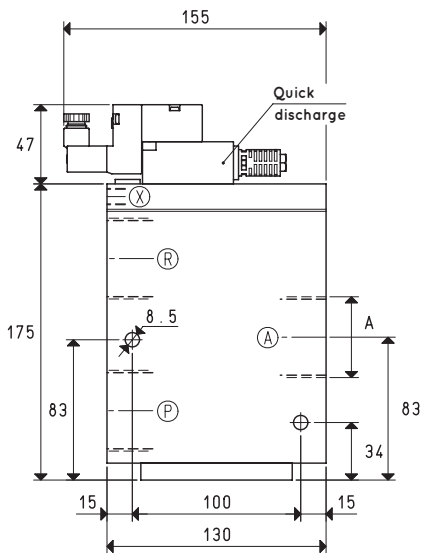

Item	A Ø	Max flow rate m³/h	Level of vacuum abs. mbar		Reaction time msec		Mouth Ø	Cross-section of passage mm²	Pressure at servo-controlled (X) *bar	Weight Kg
			min	max	energ.	de-energ.				
07 06 13	G1"1/2	230	1000	0.5	60	38	40	1256	6 ÷ 8	4.50
Spare parts								07 06 13		
Solenoid valve sealing kit with pilot membranes					item	00 07 274				
Pilot membranes for solenoid valves					item	00 07 232				

* Add the letters LP to the item for servo-controlled pressures 4 - 6 bar.

Note: Specify the voltage of the electric coil when ordering. (Example: 07 06 13 V24-CC)

The connector is not integral parts of the solenoid valve and, therefore, must be ordered separately (See accessories for solenoid valves).

Solenoid valve servo-controlled power must be supplied with non-lubricated compressed air, 5 micron filtration, according to standard ISO 8573-1 class 4.

Transformation ratio: N (newton) = Kg x 9.81 (force of gravity)

inch = $\frac{\text{mm}}{25.4}$; pounds = $\frac{\text{g}}{453.6} = \frac{\text{Kg}}{0.4536}$

Adapters for GAS - NPT threading available on page 1.134



3-WAY VACUUM SOLENOID VALVES, PILOT-OPERATED FOR LARGE CAPACITIES WITH LOW ABSORPTION ELECTRIC COIL

The growing demand by automatic machine manufacturers in the packaging sector and the lack of high-speed three-way vacuum solenoid valves on the market for capacities above 200 m³/h have led us to design and implement this new series of solenoid valves that are able to meet these needs.

Strengthened by our constant desire for research and innovation and our experience, acquired over more than forty years of operations in the vacuum sector, we have made these new solenoid valves using absolutely innovative technologies, to guarantee exceptionally low intervention times, almost negligible pressure drops, and minimal dimensions compared to the large connections and minimum electrical absorption for their powering with which they are equipped.

Furthermore, we have obtained them from aluminium block to eliminate even the slightest chance of loss due to transpiration, as perhaps could occur with a fusion.

This new series of solenoid valves for vacuums are three-way, two-position and are composed of:

- An anodised aluminium body set with attachment connections;
- Two conical HNBR shutters fitted on the aluminium pistons, pneumatically powered with spring return;
- A solenoid pilot valve powered by a low absorption fitted electrical coil which managed compressed air supply.

The composition of these valves, especially the original Teflon[®] slide system that the pistons have been equipped with, help minimise friction and internal dynamic stress, deriving high response speed and ensuring enduring operation.

They can be used normally either closed or open.

The electric coils of the solenoid pilot valve are fully plastic-coated in synthetic resin, watertight, insulation class F (up to 155°C) as per standard EN 60664, with 3 mm two-terminal electrical connections for connectors in compliance with EN 175301-803. Degree of protection IP 54; IP 65 with connector inserted.

Available for voltages 12-24V/50-60Hz and 12-24VDC.

Tolerance permitted on the nominal voltage value: ± 10%.

Maximum electric power: 2 W.

The connector can be rotated 180° on the coil and can be supplied, upon request, with LED lights, anti-interference circuit and/or with protection devices against overvoltage and polarity reversal.

A push-button device, built-in the solenoid pilot valve, allows manually opening and closing the solenoid valve.

The three-way solenoid valves are used for vacuum interception on power supply units and suction palletisers, vacuum thermoformers, vacuum packaging units, robots, feeders, bag opening units and in all those cases where rapid exchange between pump suction for vacuums and air supply into the circuit is necessary for quick restoration of atmospheric pressure.

Technical features

Working pressure: from 0.5 to 1000 absolute mbar

Servo-control pressure (X): from 4 to 8 bar

Suctioned fluid temperature: from - 5 to + 60°C

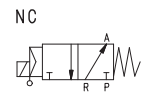
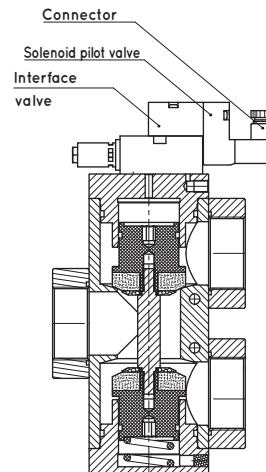
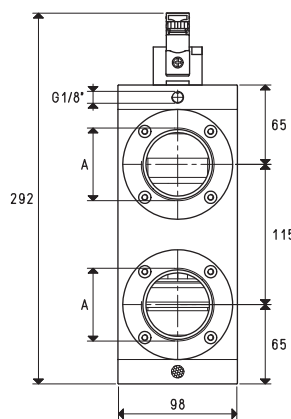
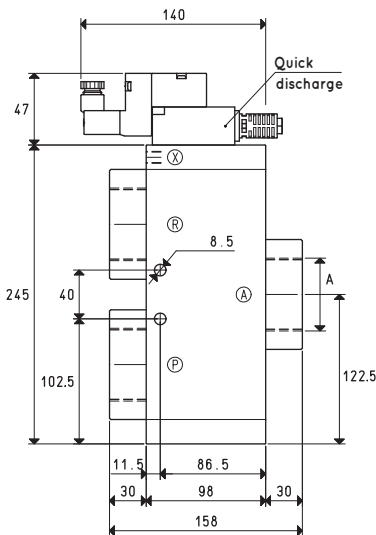
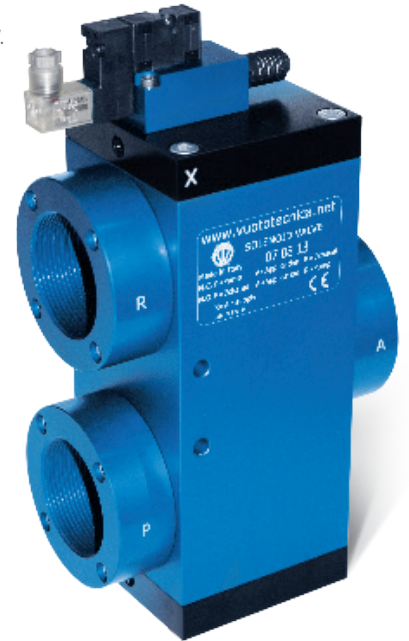

- ⊗ = Servo-controlled
- Ⓟ = Pump
- Ⓐ = Use
- Ⓡ = Discharge

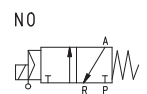

- ⊗ = Servo-controlled
- Ⓡ = Discharge
- Ⓐ = Use
- Ⓟ = Pump

Item	A	Max flow rate	Level of vacuum		Reaction time		Mouth	Cross-section of passage	Pressure at servo-controlled (X)	Weight
			abs. mbar	min max	msec	energ. de-energ.				
07 08 13	G2"	390	1000	0.5	78	50	52	2123	4 ÷ 8	5.87
Spare parts			07 08 13							
Solenoid valve sealing kit	item		00 07 379							

Note: Specify the voltage of the electric coil when ordering. (Example: 07 08 13 V24-CC)

The connector is not integral parts of the solenoid valve and, therefore, must be ordered separately (See accessories for solenoid valves).

Solenoid valve servo-controlled power must be supplied with non-lubricated compressed air, 5 micron filtration, according to standard ISO 8573-1 class 4.

Transformation ratio: N (newton) = Kg x 9.81 (force of gravity)

inch = $\frac{\text{mm}}{25.4}$; pounds = $\frac{\text{g}}{453.6} = \frac{\text{Kg}}{0.4536}$

Adapters for GAS - NPT threading available on page 1.134

3-WAY VACUUM SOLENOID VALVES, PILOT-OPERATED FOR LARGE CAPACITIES WITH LOW ABSORPTION ELECTRIC COIL

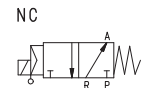
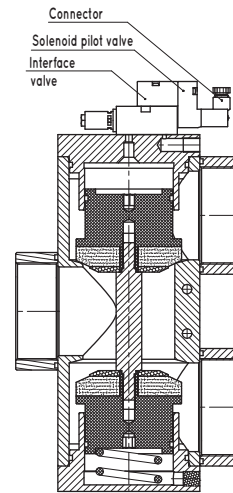
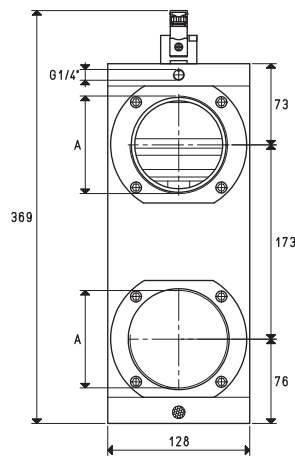
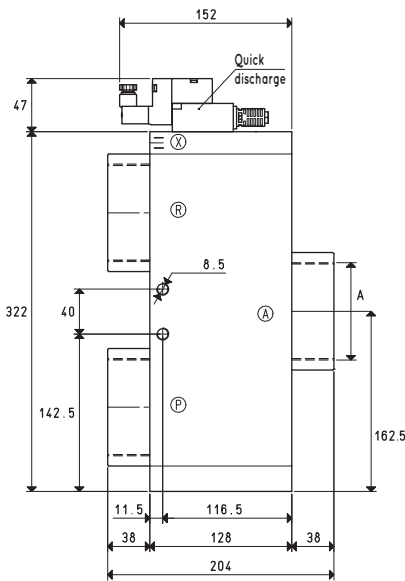

- ⊗ = Servo-controlled
- Ⓟ = Pump
- Ⓐ = Use
- Ⓡ = Discharge

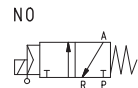

- ⊗ = Servo-controlled
- Ⓡ = Discharge
- Ⓐ = Use
- Ⓟ = Pump

Item	A	Max flow rate	Level of vacuum		Reaction time		Mouth	Cross-section of passage	Pressure at servo-controlled (X)	Weight
			abs. mbar	min	max	msec				
07 09 13	G3"	750	1000	0.5	132	84	80	5024	4 ÷ 8	11.80
Spare parts			07 09 13							
Solenoid valve sealing kit			item	00 07 383						

Note: Specify the voltage of the electric coil when ordering. (Example: 07 09 13 V24-CC)

The connector is not integral parts of the solenoid valve and, therefore, must be ordered separately (See accessories for solenoid valves).

Solenoid valve servo-controlled power must be supplied with non-lubricated compressed air, 5 micron filtration, according to standard ISO 8573-1 class 4.

Transformation ratio: N (newton) = Kg x 9.81 (force of gravity)

inch = $\frac{\text{mm}}{25.4}$; pounds = $\frac{\text{g}}{453.6} = \frac{\text{Kg}}{0.4536}$

Adapters for GAS - NPT threading available on page 1.134