



DIRECT DRIVE 3-WAY VACUUM SOLENOID VALVES WITH LOW ABSORPTION ELECTRIC COIL

These direct drive three-way, two-position vacuum solenoid valves feature conical shutters servo-controlled by the vacuum. They are normally closed as standard, but they can be supplied normally open upon request.

They are composed of an anodised aluminium body where the connections are located, two silicone shutters assembled onto a stainless steel stem and a membrane in special reinforced compound. A solenoid pilot valve activated by a built-in electric coil manages the vacuum at the servo-control. The operating principle of these solenoid valves is based on the pressure differential between the vacuum pump or generator and the pressure of the suctioned air. By addressing this "differential pressure" to the servo-control via the solenoid pilot valve, the shutters can be controlled without compressed air or springs.

Due to their operating principle stated above, they are not recommended on plants with rough vacuum levels (below 850 absolute mbar, equal to 15 % vacuum).

The lack of springs, frictions and internal dynamic stresses favours a high response speed and guarantees long lasting operation.

The electric coils of the solenoid pilot valve are fully plastic-coated in synthetic resin, watertight, insulation class F (up to 155°C) as per standard VDE, with 3 mm two-terminal electrical connections for connectors in compliance with EN 175301-803 (ex DIN 43650) - C.

Protection degree IP 54; IP 65 with connector inserted.

Available for voltages 12-24V/50-60Hz and 12-24VDC.

Tolerance permitted on the nominal voltage value: $\pm 10\%$.

Maximum electric power: 2 W

The connector can be rotated 180° on the coil and can be supplied, upon request, with LED lights, anti-interference circuit and/or with protection devices against overvoltage and polarity reversal. A push-button device, built-in the solenoid pilot valve, allows manually opening and closing the solenoid valve.

The solenoid valves in this series, along with the uses described for the 07 .. 11 series, can be used on plants with no compressed air.

The solenoid valve must be always chosen according to the flow rate and, therefore, to the vacuum pump or generator suction connection.

Technical features

Operating pressure: from 0.5 to 850 absolute mbar

Temperature of suctioned fluid: from -5 to +60°C

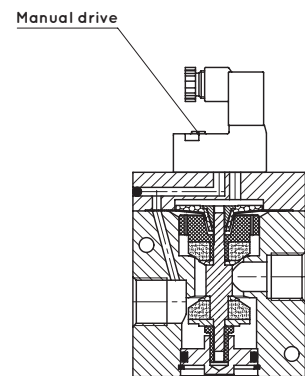
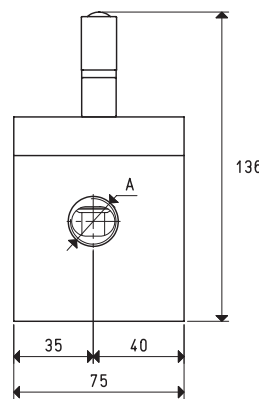
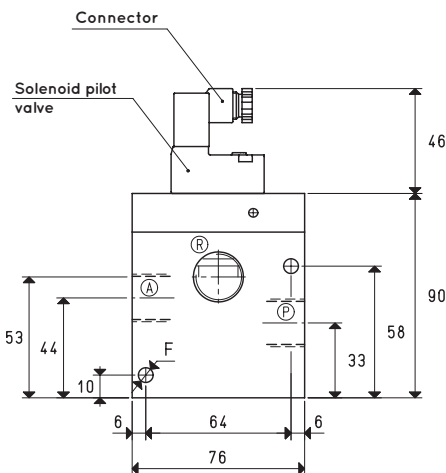
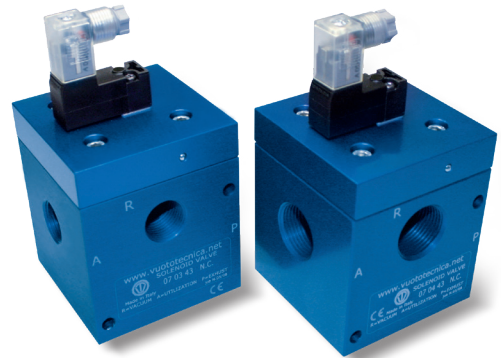

NC

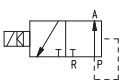

R = Pump
A = Use
P = Discharge

NO

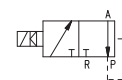

R = Discharge
A = Use
P = Pump

| Item | A Ø | Max flow rate m³/h | Level of vacuum abs. mbar | | Reaction time msec | | Mouth Ø | Cross-section of passage mm² | F Ø | Weight Kg |
|-------------|--------|-----------------------|------------------------------|-----|-----------------------|-----------|------------|------------------------------------|--------|--------------|
| | | | min | max | energ. | de-energ. | | | | |
| 07 03 43 NC | G1/2" | 20 | 850 | 0.5 | 33 | 17 | 15 | 176 | 6.5 | 1.35 |
| 07 03 43 NO | | | | | 22 | 20 | | | | |
| 07 04 43 NC | G3/4" | 40 | 850 | 0.5 | 33 | 17 | 20 | 314 | 6.5 | 1.30 |
| 07 04 43 NO | | | | | 22 | 20 | | | | |

Note: Specify the voltage of the electric coil when ordering. (Example: 07 03 43 NC V24-CC)

The connector is not integral parts of the solenoid valve and, therefore, must be ordered separately (See accessories for solenoid valves).

Transformation ratio: N (newton) = Kg x 9.81 (force of gravity)

inch = $\frac{\text{mm}}{25.4}$; pounds = $\frac{\text{g}}{453.6} = \frac{\text{Kg}}{0.4536}$

Adapters for GAS - NPT threading available on page 1.130

DIRECT DRIVE 3-WAY VACUUM SOLENOID VALVES WITH LOW ABSORPTION ELECTRIC COIL

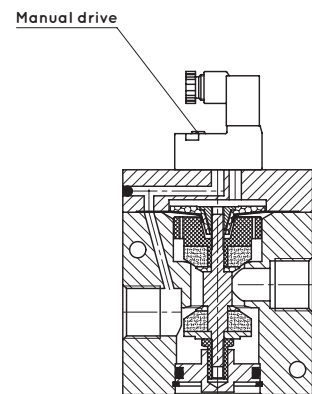
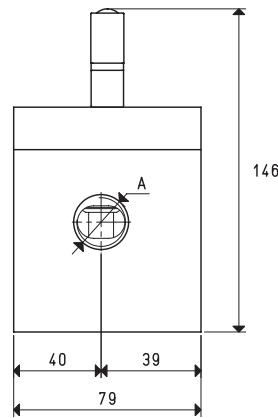
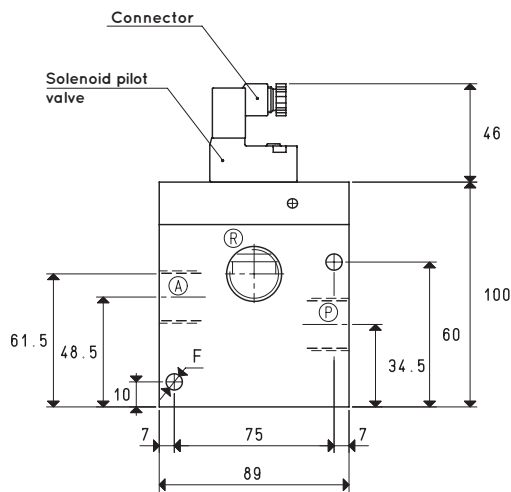

NC

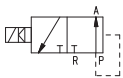

R = Pump
A = Use
P = Discharge

NO

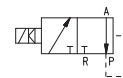

R = Discharge
A = Use
P = Pump

| Item | A Ø | Max flow rate m ³ /h | Level of vacuum | | Reaction time | | Mouth Ø | Cross-section of passage mm ² | F Ø | Weight Kg |
|--------------------|--------|------------------------------------|------------------|-----|----------------|-----------|------------|---|--------|--------------|
| | | | abs. mbar min | max | msec energ. | de-energ. | | | | |
| 07 05 43 NC | G1" | 90 | 850 | 0.5 | 42 | 20 | 25 | 490 | 6.5 | 1.65 |
| 07 05 43 NO | | | | | 28 | 22 | | | | |

Note: Specify the voltage of the electric coil when ordering. (Example: 07 05 43 NC V24-CC)

The connector is not integral parts of the solenoid valve and, therefore, must be ordered separately (See accessories for solenoid valves).