

VACUUM PUMPS VTLP 75/G1, 90/G1 and 105/G1 WITH DISPOSABLE LUBRICATION

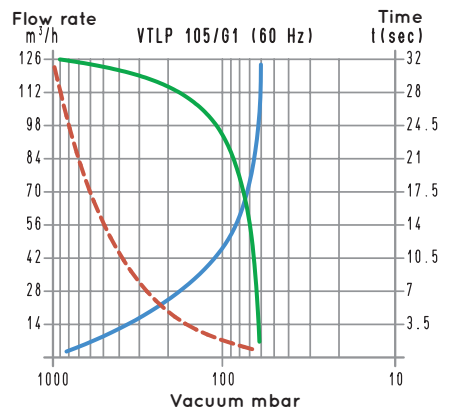
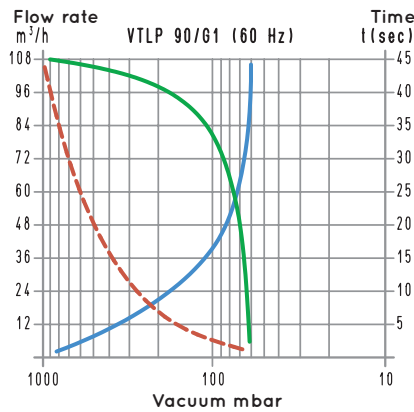
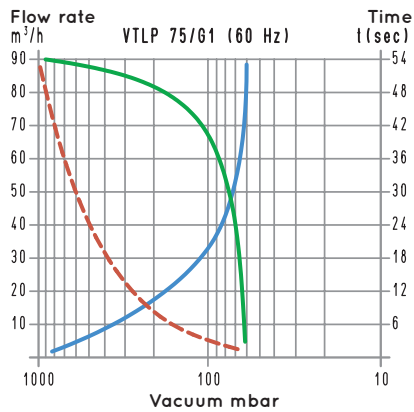
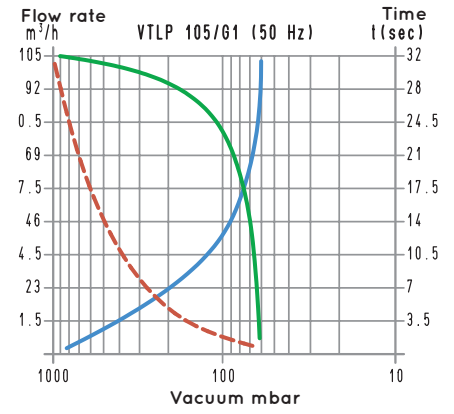
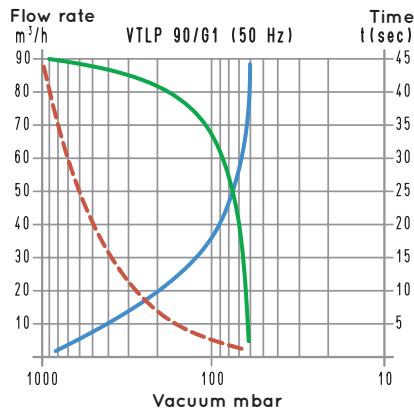
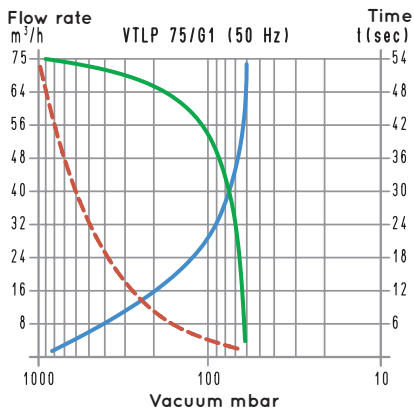
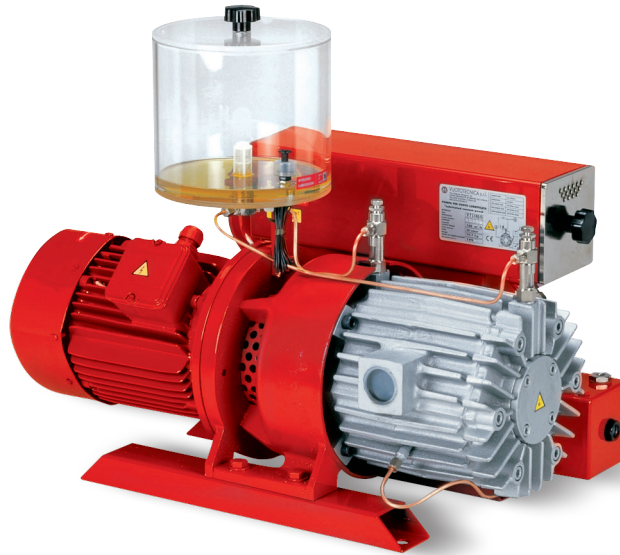

To calculate the emptying time of a volume of V_1 , use the following formula: $t_1 = \frac{t \times V_1}{100}$

- Curve relative to the flow rate (referring to the suction pressure)
- - - Curve relative to the flow rate (referring to a 1013 mbar pressure)
- Curve regarding the emptying time of a 100-litre volume

- V_1 : Volume to be emptied (l)
- t_1 : time to be calculated (sec)
- t : time obtained in the table (sec)



VACUUM PUMPS VTLP 75/G1, 90/G1 and 105/G1 WITH DISPOSABLE LUBRICATION

3D drawings are available on vuototecnica.net

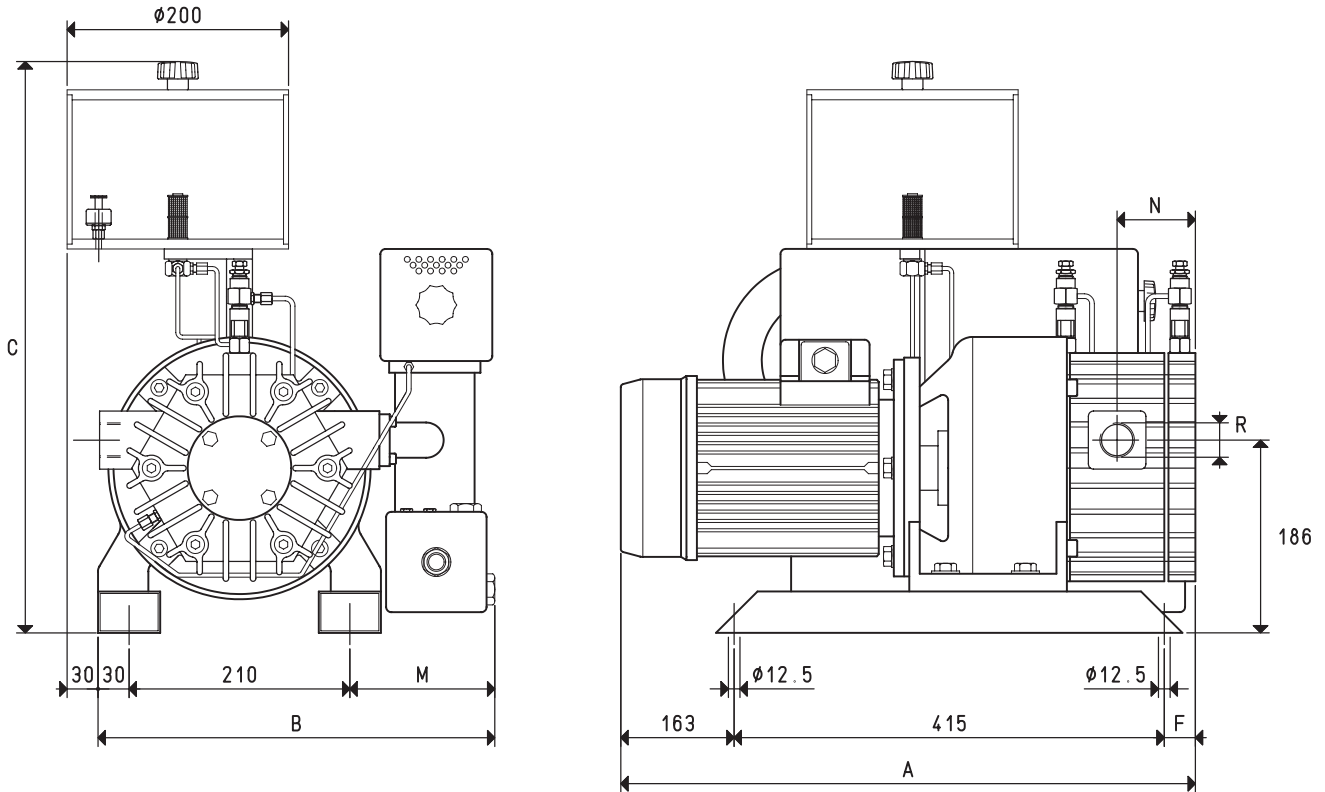

Item		VTLP 75/G1		VTLP 90/G1		VTLP 105/G1	
Frequency		50Hz	60Hz	50Hz	60Hz	50Hz	60Hz
Flow rate	m ³ /h	75.0	90.0	90.0	108.0	105.0	126.0
Final pressure	mbar abs.	50		50		50	
Motor performance 3~	volt	230/400±10%	265/460±10%	230/400±10%	265/460±10%	230/400±10%	265/460±10%
Motor power 3~	Kw	2.20	2.70	3.00	3.60	3.00	3.60
Motor protection	IP	55		55		55	
Rotation speed	g/min ⁻¹	1450	1735	1440	1700	1440	1700
Motor shape		B5		B5		B5	
Motor size		100		100		100	
Noise level	dB(A)	70	72	71	73	72	74
Max weight 3~	kg	78.3		85.8		99.4	
A		640		660		690	
B		415		430		430	
C		575		575		620	
F		62		82		112	
M		145		150		160	
N		80		92		122	
R	Ø gas	G1"1/4		G1"1/4		G1"1/2	
Accessories and Parts		VTLP 75/G1		VTLP 90/G1		VTLP 105/G1	
Oil charge	L	3.8		3.8		3.8	
Lubricating oil	type	ISO 150		ISO 150		ISO 150	
Deoiling cartridge	item	00 VTL 75G1 29		00 VTL 90G1 29		00 VTL 105G1 29	
6 vanes	item	00 VTL 75G1 10		00 VTL 90 G110		00 VTL 105 G110	
Sealing kit	item	00 KIT VTL 75G1		00 KIT VTL 90G1		00 KIT VTL 105G1	
Check valve	item	10 06 10		10 06 10		10 07 10	
Suction filter	item	FB 40/FC 40		FB 40/FC 40		FB 50/FC 50	
Oil level switch	item	00 LP VTL 99		00 LP VTL 99		00 LP VTL 99	
Oil filter	item	00 LP VTL 40		00 LP VTL 40		00 LP VTL 40	
Adjustable drip oiler	item	00 VTL 00 11		00 VTL 00 11		00 VTL 00 11	

Transformation ratio: N (newton) = Kg x 9.81 (force of gravity)

inch = $\frac{\text{mm}}{25.4}$; pounds = $\frac{\text{g}}{453.6} = \frac{\text{Kg}}{0.4536}$

cfm = m³/h x 0.588; inch Hg = mbar x 0.0295; psi = bar x 14.6