

To calculate the emptying time of a volume of V_1 , use the following formula: $t_1 = \frac{t \times V_1}{100}$

- Curve relative to the flow rate (referring to the suction pressure)
- - - Curve relative to the flow rate (referring to a 1013 mbar pressure)
- Curve regarding the emptying time of a 100-litre volume

- V_1 : Volume to be emptied (l)
- t_1 : time to be calculated (sec)
- t : time obtained in the table (sec)

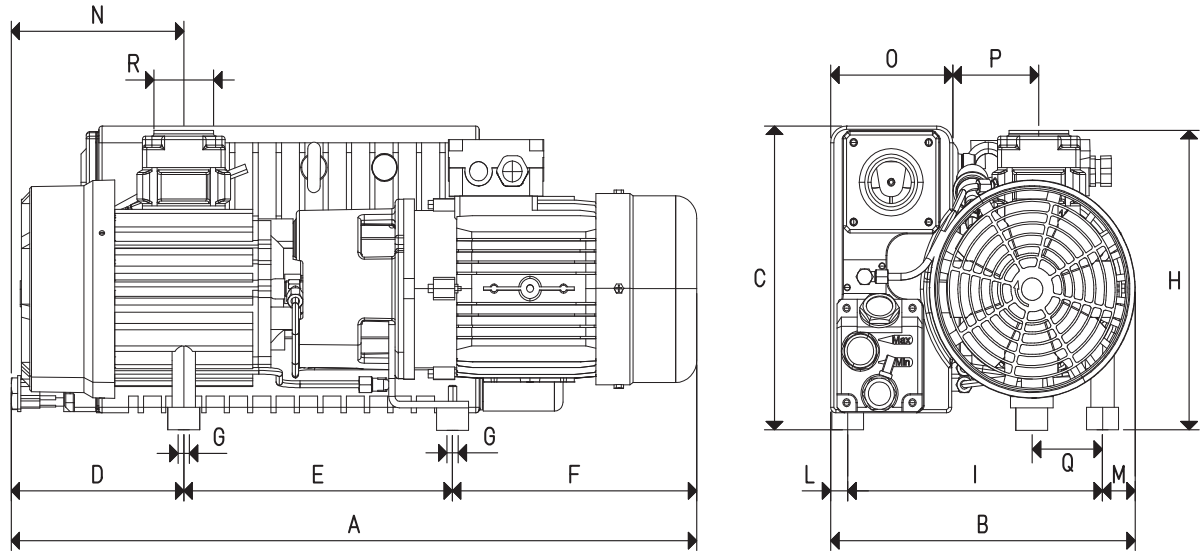

3D drawings are available on vuotecnica.net

Item		RVP 40	
Frequency		50 Hz	60 Hz
Flow rate	m ³ /h	40.0	48.0
Final pressure	mbar abs.	0.5	
H₂O steam quantity permitted	Kg/h	0,7	
Motor performance 3~	Volt	230/400 ± 10%	275/480 ± 10%
Motor power 3~	Kw	1.10	1.35
Motor protection	IP	55	
Rotation speed	g/min ⁻¹	1450	1740
Motor shape		B14	
Motor size		100	
Noise level	dB(A)	64	65
Max weight	Kg	49.0	
A		645	
B		286	
C		266	
D		157	
E		335	
F		225	
G	∅	M8	
H		260	
I		240	
L		15	
M		31	
N		157	
O		115	
P		80	
Q		66	
R	∅ gas	G1"1/4	
Accessories and Parts		RVP 40	
Oil charge	L	1.25	
Lubricating oil	type	VT OIL 100	
Oil filter	item	00 RVP 40 07	
Deoiling cartridge	item	00 RVP 40 05	
3 vanes	item	00 RVP 40 04	
Sealing kit	item	00 RVP 40 06	
Check valve	item	00 RVP 40 03	
Suction filter	item	FC 35	
Ballast valve	item	integrated	

Transformation ratio: N (newton) = Kg x 9.81 (force of gravity)

inch = $\frac{\text{mm}}{25.4}$; pounds = $\frac{\text{g}}{453.6} = \frac{\text{Kg}}{0.4536}$

cfm= m³/h x 0.588; inch Hg= mbar x 0.0295; psi= bar x 14.6