



PNEUMATIC BLOWING PUMPS PS

3D drawings are available on vuototecnica.net

A newly designed range of ejectors has allowed creating this range of pneumatic blowing pumps featuring an excellent ratio between the amount of consumed air and generated air, as well as the ability to adjust the pressure and flow rate according to the supply air pressure. These pumps are powered with compressed air with a pressure ranging from 1 to 6 bar and have a blowing flow rate between 18 and 425 m³/h, measured at a normal atmospheric pressure of 1013 mbar.

When designing these pumps, our attention was focused on noise. In fact, they are perfectly soundproofed and there are no moving parts subject to wear and vibrations. All this results in an extremely silent operation.

Moreover, as they are based on the Venturi principle, they do not develop heat.

They are equipped as standard with a filter/pressure reducer unit for the supply air and a filter with microporous cartridge located on the air inlet connection which can keep the finest dust and impurities.

The excellent filtration of the compressed air supply and intake air allows the intake of air free from oil, water condensates or impurities from between the sheets of paper to be separated in the working environment, with no pollution.

The use of light alloys for making these pumps has allowed a considerable reduction of their weight thus allowing them to be directly installed onto the machine.

Thanks to their static operating principle, maintenance is reduced to a only a simple regular cleaning of the filters.

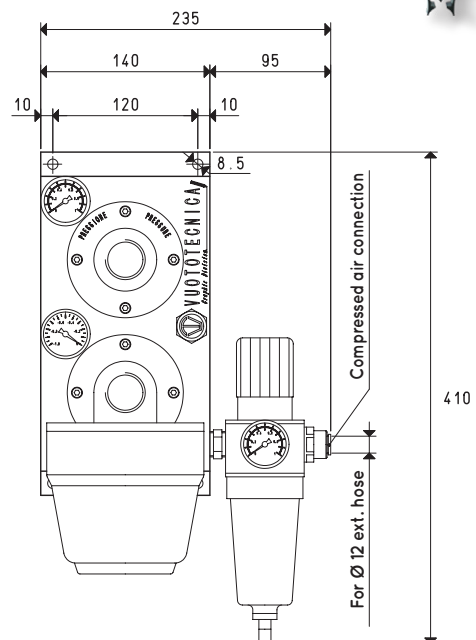
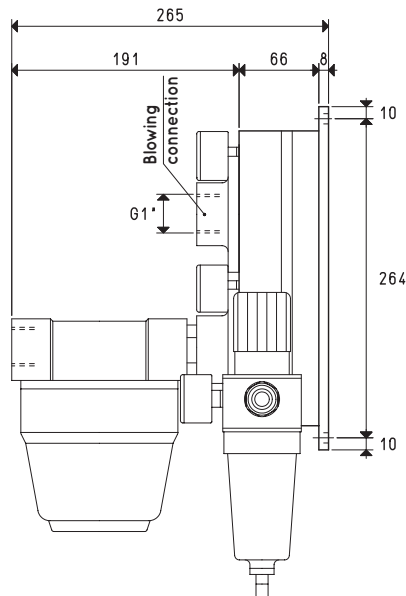

Item		PS 40					
Supply pressure	bar	1	2	3	4	5	6
Maximum blowing pressure	bar	0.1	0.2	0.3	0.5	0.7	0.8
Air consumption	NI/s	1.0	1.5	2.0	2.3	2.7	3.2
Blown air flow rate	m ³ /h	18	28	37	44	48	53
Weight	Kg	6.3					
Item		PS 70					
Supply pressure	bar	1	2	3	4	5	6
Maximum blowing pressure	bar	0.1	0.2	0.3	0.5	0.7	0.8
Air consumption	NI/s	2.0	3.0	4.1	4.9	5.7	6.6
Blown air flow rate	m ³ /h	36	57	72	83	93	104
Weight	Kg	6.3					
Item		PS 100					
Supply pressure	bar	1	2	3	4	5	6
Maximum blowing pressure	bar	0.1	0.2	0.3	0.5	0.7	0.8
Air consumption	NI/s	3.0	4.6	6.2	7.2	8.5	9.8
Blown air flow rate	m ³ /h	38	73	97	114	129	144
Weight	Kg	6.3					
Operating temperature	°C	-20 / +80					

NOTE: All vacuum values indicated in the table are valid at the normal atmospheric pressure of 1013 mbar and obtained with a constant supply pressure.

Vacuum generator supply must be carried out with non-lubricated compressed air, 5 micron filtration, in accordance with standard ISO 8573-1 class 4.

Transformation ratio: N (newton) = Kg x 9.81 (force of gravity)

inch = $\frac{\text{mm}}{25.4}$; pounds = $\frac{\text{g}}{453.6} = \frac{\text{Kg}}{0.4536}$

Adapters for GAS - NPT threading available on page 1.130