



DIGITAL VACUUM AND PRESSURE SWITCHES WITH TWO-COLOUR DISPLAY

3D drawings are available on vuototecnica.net

These devices are also enclosed within a robust ABS container. They are carefully calibrated and at compensated temperature, ensuring high-precision measurement values. Detected values are viewed on the main two-colour (red and green) display and programmable by the user to set different conditions. Setting values are easily viewable on a secondary display within the command panel. Two luminous indicators pertaining to outlets 1 and 2 indicate the switching status of both digital and the analogue output signals.

The switching outputs are completely independent.

The switching points within the scale values, including hysteresis, are easily programmable via the buttons located on the control panel. Additional functions are also programmable, such as comparison between two values, NO and NC contacts, choice of measurement unit, programmed value and function blocking, etc. The connection to the vacuum may be established by means of a male G 1/8" or female M5 double threading connection. It is possible to establish an electric connection by means of a removable, rapid installation data cable, supplied as standard.

Digital vacuum and pressure switches are suitable for measuring and controlling dry air and non-corrosive gases. They are recommended in all those cases that require a signal when a certain level of vacuum is reached set for safety, for starting a cycle, for checking the cup grip, etc. Moreover, the hysteresis function allows managing the vacuum generator compressed air supply, allowing considerable energy saving.

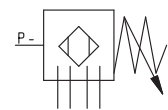
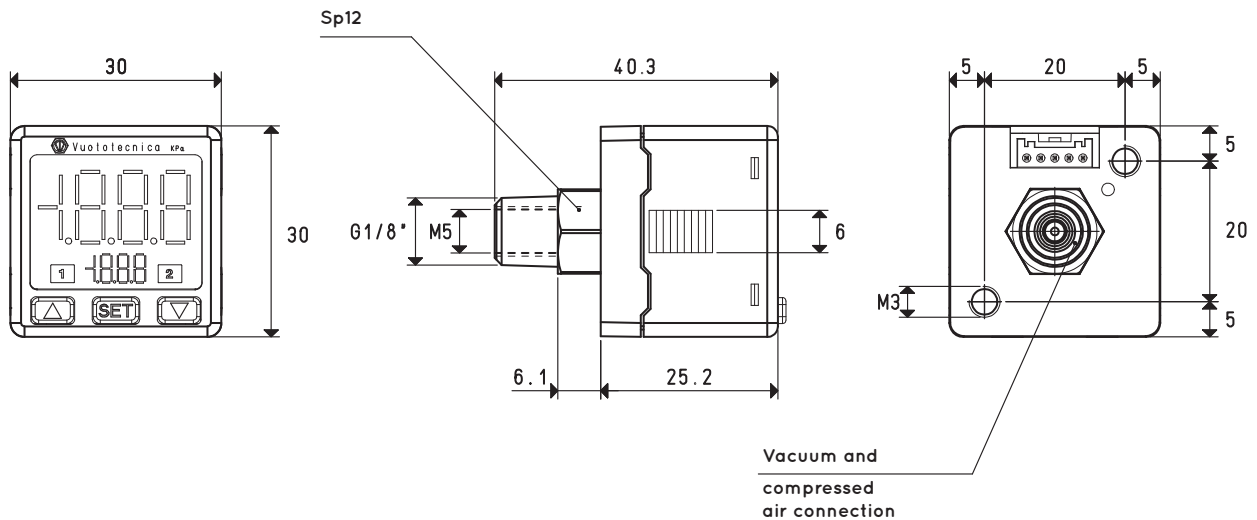



WIRING DIAGRAMS

PNP

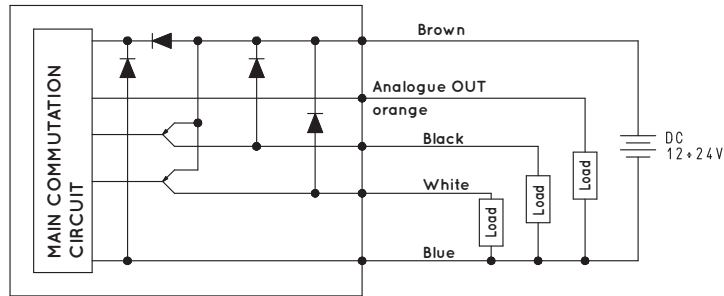

Characteristics and electrical specifications	Item 12 40 10 Vacuum switch	Art. 12 40 12 Vacuum switch	Item 12 40 20 Vacuum Switch - Pressure Switch
Adjustment range	from 0 to -1 bar	from 0 a -1 bar	from -1 to 10 bar
Maximum overpressure	3 bar	3 bar	15 bar
Minimum detectable values	1 mbar 0.001 Kgf/cm ² 0.001 bar 0.01 psi 0.1 inHg	1 mbar 0.001 Kgf/cm ² 0.001 bar 0.01 psi 0.1 inHg	10 mbar 0.01 Kgf/cm ² 0.01 bar 0.1 psi -
Operating voltage	12 - 24 VDC ±10% (Protection against polarity inversion)		
Electrical absorption	≤40 mA		
Digital output	2 PNP, maximum commutation current 125 mA		
Analogue output	1 analogue, 4 - 20 mA ±2.5% F.S. 1 ÷ 5 V ±2,5% F.S. for Item 12 40 12		
Display tolerance	≤ ±2% F.S. ±1 digit		
Reaction time	≤ 2.5 ms		
Hysteresis	Adjustable		
Repeatability	±0.2% F.S. ±1 digit of the measuring range		
Display	7 segments, main two-colour (red - green) display, secondary display (orange)		
Insulation resistance	50 MΩ to 500 VDC		
Test voltage	1000 VAC, 1 min		
Degree of protection	IP 40		
Environmental operating conditions			
Installation position	Any		
Measurable fluids	Non-corrosive gas and dry air		
Operating temperature	0 - +50 °C		
Storage temperature	-20 - +60 °C		
Interference emission	In compliance with EN 55011, Group 1, class B		
Resistance to interference	In compliance with EN 61326 - 1		
Characteristics and mechanical specifications			
Container material	ABS plastic - PC		
Connection material	Nickel-plated brass		
Weight	80 g, including electrical cable		
Electrical connection	4-wire 2 m cable		
Connection to the fluid	Male G 1/8" or female M5 threading		
Accessories			
Fixing kit	wall - Item 00 12 40 table - Item 00 12 41 panel - Item 00 12 42 panel + protection - Item 00 12 43		