

MINI VACUUM CUP HOLDERS WITH MALE AND FEMALE THREADED CONNECTORS

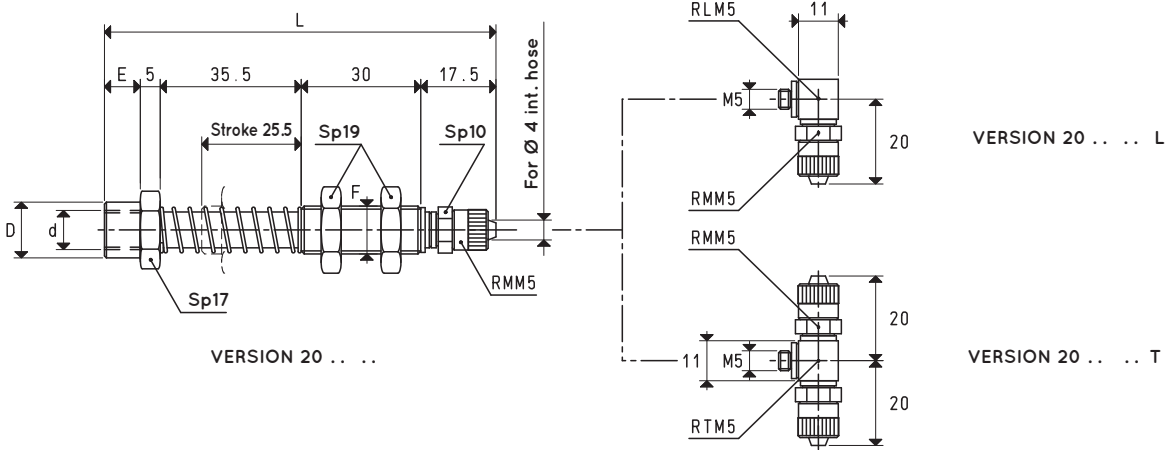

The cup holders described on these pages share the same features as the previously described ones, but differ for their brass stem, which has 1/8" and 1/4" gas threaded female connection, for the exclusive installation of cups with male threaded support and for the vacuum connection, which can either be radial or axial, upon request.

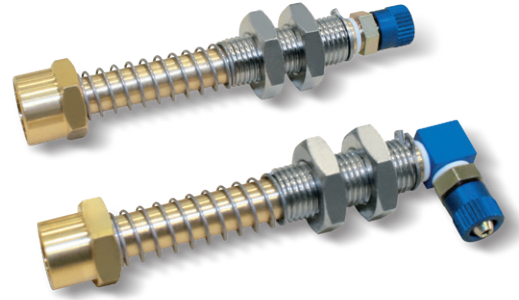

VACUUM CUP HOLDERS WITH STRAIGHT QUICK COUPLER FOR PLASTIC HOSE Ø 4 X 6

Item	d Ø	D Ø	E	F Ø	L	Weight g
20 06 35	M5	7.0	3.5	M12 x 1.25	91.5	74
20 07 35	M8	12.0	9	M12 x 1.25	97	76
20 10 38	G1/8"	14.0	9	M12 x 1.25	97	78
20 10 48	G1/4"	16.5	9	M12 x 1.25	97	78

Note: To order vacuum cup holders with L or T fittings, add the letter L or T to the code.

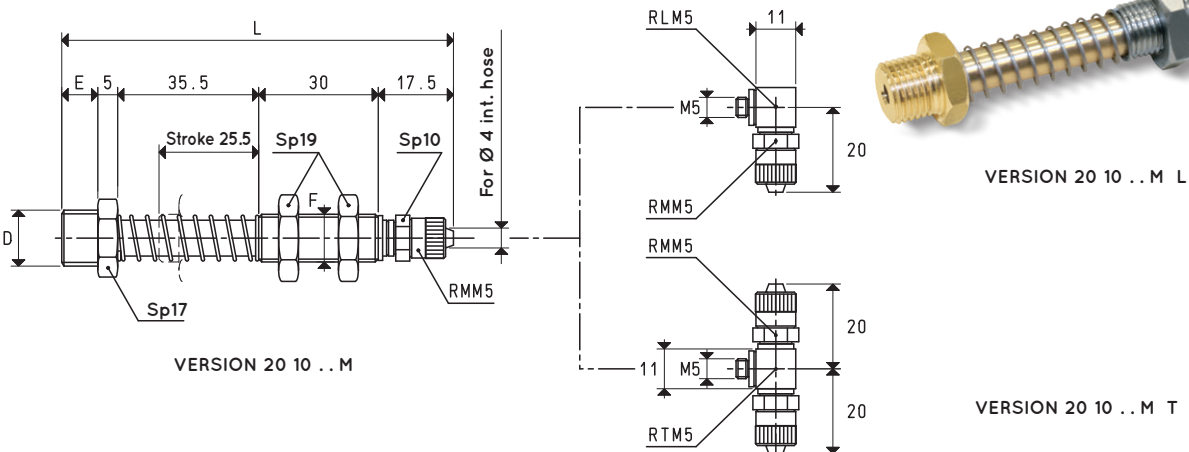
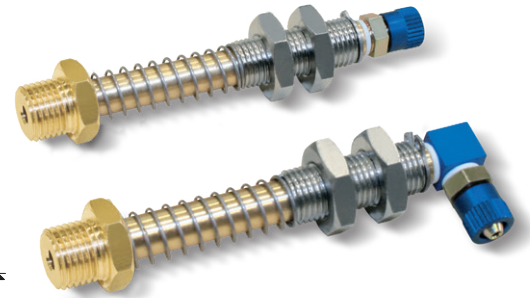

VACUUM CUP HOLDERS WITH STRAIGHT QUICK COUPLER FOR PLASTIC HOSE Ø 4 X 6

Item	D Ø	E	F Ø	L	Weight g
20 10 38 M	G1/8"	8	M12 x 1.25	96	78
20 10 48 M	G1/4"	10	M12 x 1.25	98	76
20 10 58 M	G3/8"	10	M12 x 1.25	98	76

Note: To order vacuum cup holders with L or T fittings, add the letter L or T to the code.

Transformation ratio: N (newton) = Kg x 9.81 (force of gravity) inch = $\frac{\text{mm}}{25.4}$; pounds = $\frac{\text{g}}{453.6} = \frac{\text{Kg}}{0.4536}$



MINI VACUUM CUP HOLDERS WITH MALE AND FEMALE THREADED CONNECTORS

3D drawings are available on vuototecnica.net

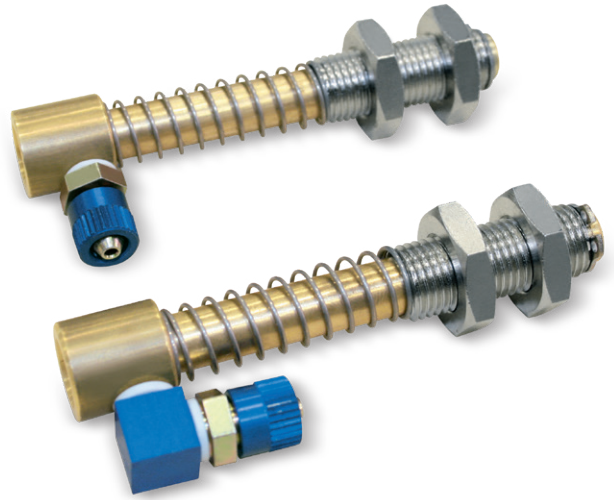
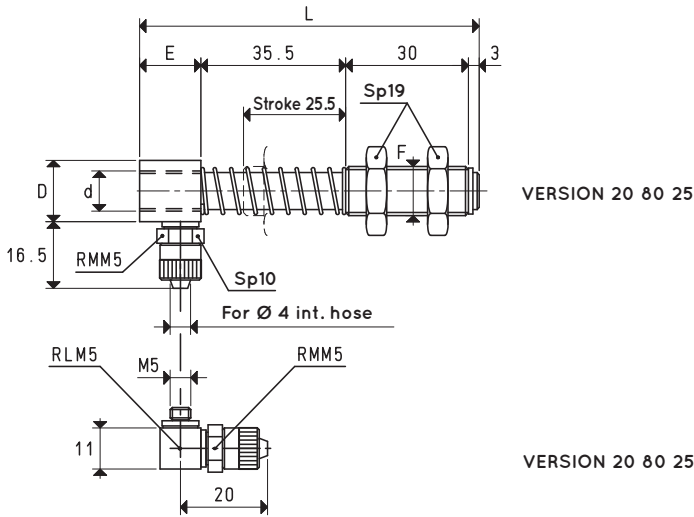

VACUUM CUP HOLDERS WITH STRAIGHT QUICK COUPLER FOR PLASTIC HOSE Ø 4 X 6

Item	d Ø	D Ø	E	F Ø	L	Weight g
20 80 25	G1/8"	15	15	M12 x 1.25	83.5	82

Note: To order vacuum cup holders with L fittings, add the letter L to the code.

MINI VACUUM CUP HOLDERS WITH BUILT-IN SPRING

For a further bulk and weight reduction, as well as to meet the requirements of discharge automations for plastic moulding press manufacturers, these cup holders are made with a built-in spring and an anodised aluminium cup fixing stem. Also these cup holders allow for the installation of cups with male threaded support only. The particular shape of the brass drive bush for fastening the cup holder to the automation prevents any rotation of the stem and, therefore, of the cup. The vacuum connection is radial.

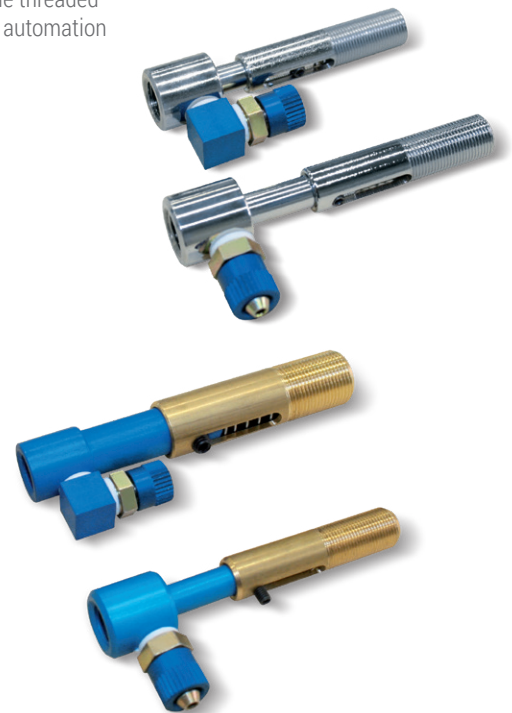
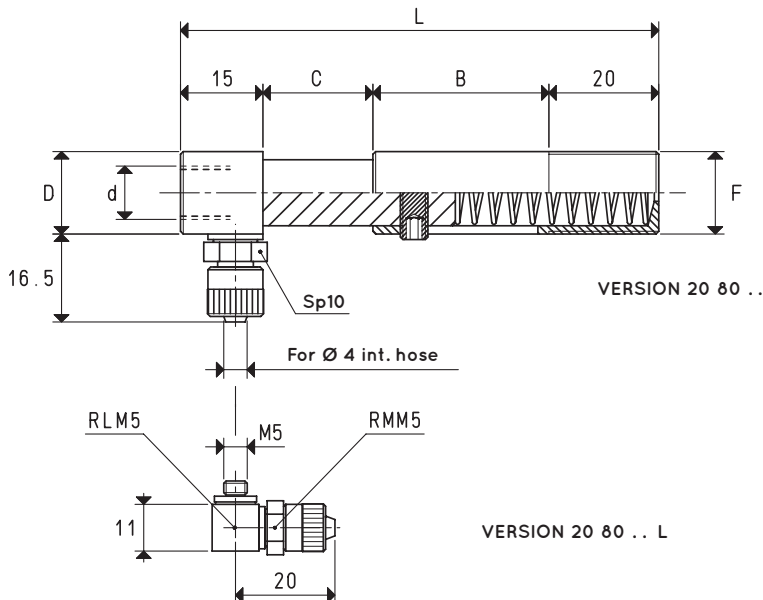

VACUUM CUP HOLDERS WITH STRAIGHT QUICK COUPLER FOR PLASTIC HOSE Ø 4 X 6

Item	B	C stroke	d Ø	D Ø	F Ø	L	Weight g
20 80 15	22	15	G1/8"	15	M10 x 0.75	72	26
20 80 20	32	20	G1/8"	15	M15 x 1.00	87	42

Note: To order chrome-plated iron, add the letters FC to the item.

To order vacuum cup holders with L fittings, add the letter L to the code.

Transformation ratio: N (newton) = Kg x 9.81 (force of gravity)

inch = $\frac{\text{mm}}{25.4}$; pounds = $\frac{\text{g}}{453.6} = \frac{\text{Kg}}{0.4536}$